

# Vibration Measurement and Analysis

- Why Frequency Analysis
- Spectrum or Overall Level
- Filters
- Linear vs. Log Scaling
- Amplitude Scales
- Vibration Parameters
- The Detector/Averager
- Signal vs. System analysis



BA 7676-12, 1

Brüel & Kjær 

## Abstract

The lecture explains the different ways signals can be treated using detectors and filters/analysers. It discusses the presentation of data using different axis and the way to combine analysis type with scale type. The fundamental rule of the BT product and selection of filter/analysis type is also covered together with the choice of parameter. Finally signal vs. system analysis is briefly discussed.

Copyright© 1998  
Brüel & Kjær Sound and Vibration Measurement A/S  
All Rights Reserved

**LECTURE NOTE**

English BA 7676-12

**Brüel & Kjær** 

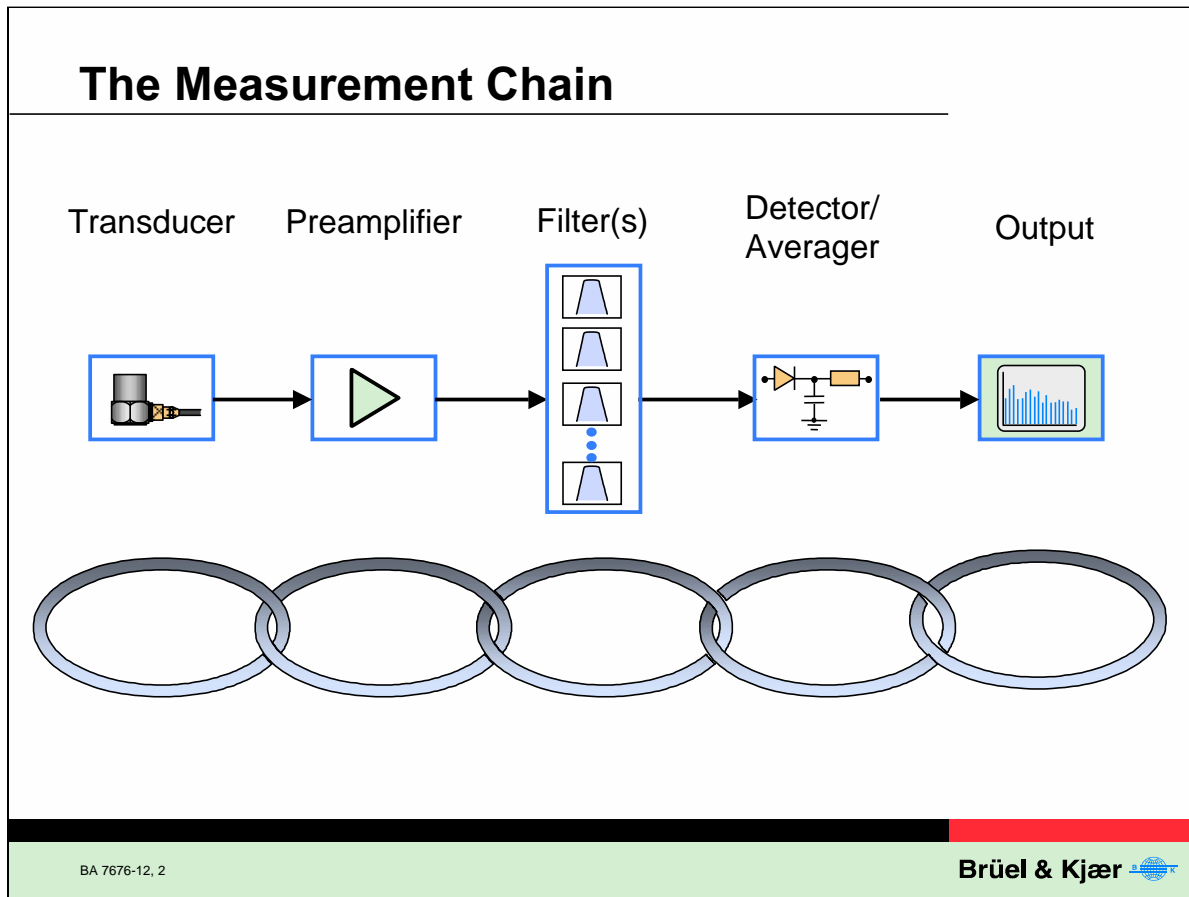

### The Measurement Chain

Remember: The system is never stronger than the weakest link in the chain.

Having covered the transducers and preamplifiers in the previous lecture, we have come to the last part of the chain, the ways of analysing the output signals of the preamplifier.

After analysis, which today can have many different forms, the result will be presented as an output to screen, paper or storage medium.

As this is what the user normally will see, it is imperative to choose a suitable output format as discussed later in this lecture.

## Why Make a Frequency Analysis

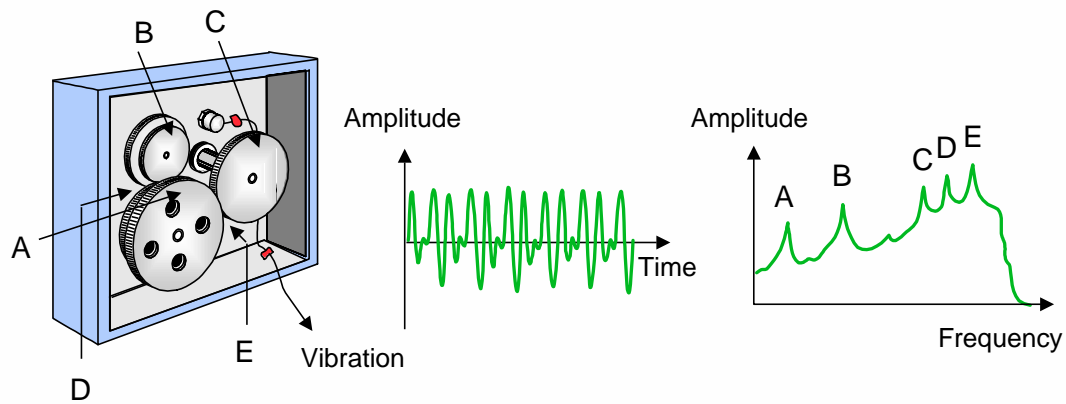

BA 7676-12, 3

Brüel & Kjær 

### The role of frequency analysis

The frequency spectrum gives in many cases a detailed information about the signal sources which cannot be obtained from the time signal. The example shows measurement and frequency analysis of the vibration signal measured on a gearbox. The frequency spectrum gives information on the vibration level caused by rotating parts and tooth meshing. It hereby becomes a valuable aid in locating sources of increased or undesirable vibration from these and other sources.

## Frequency Analysis

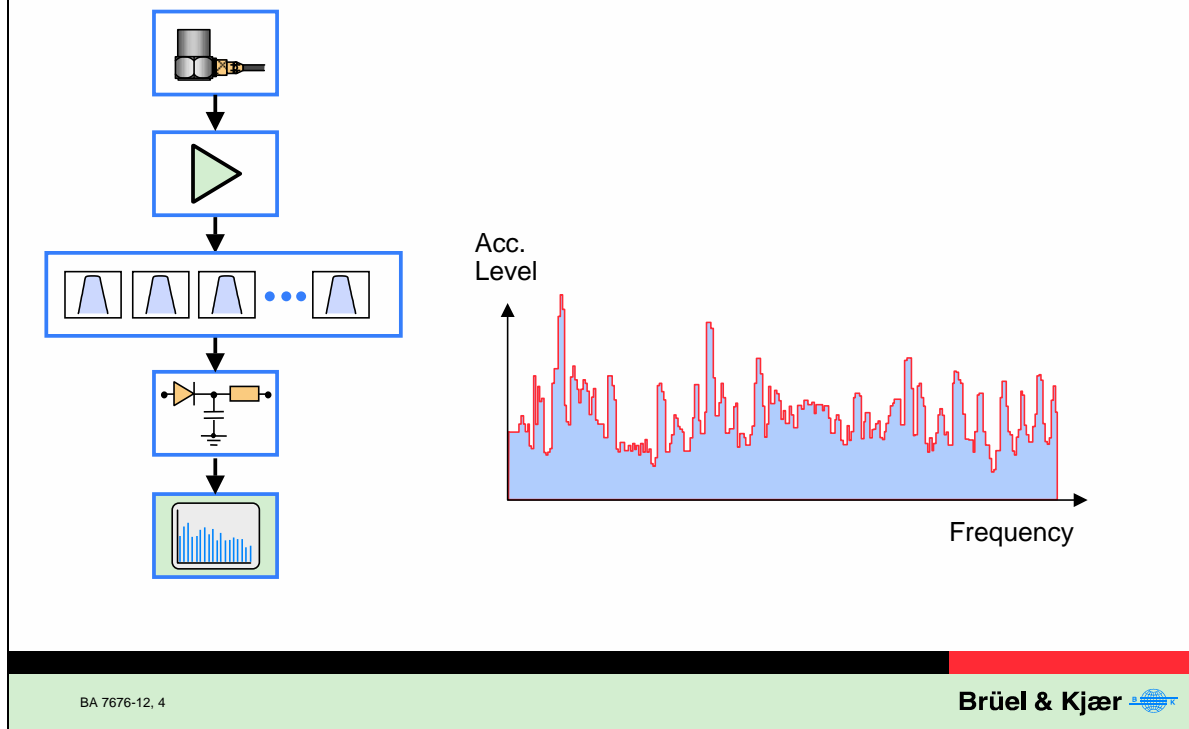

BA 7676-12, 4

Brüel & Kjær 

### Frequency Analysis

The process of Frequency Analysis is as follows: By sending a signal through a filter and at the same time sweeping the filter over the frequency range of interest (or having a bank of filters) it is possible to get a measure of the signal level at different frequencies. The result is called a Frequency Spectrum.

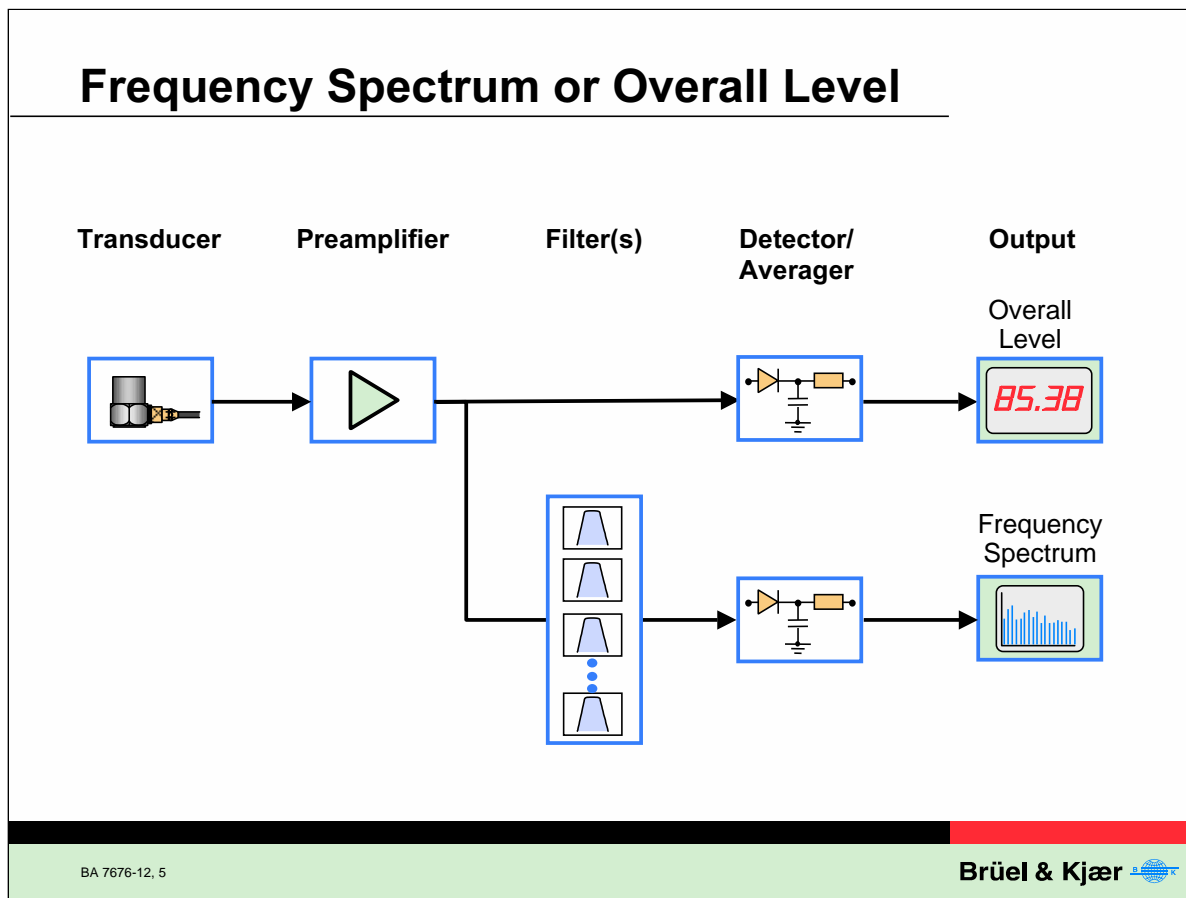

### Overall level

The simplest way to express the condition of any system is to assign only one number to it. This is often done using the RMS detector output, and this gives a number expressing the vibration energy level. However it does not give much possibility to make any kind of diagnosis. For that we need more parameters.

### The role of frequency analysis

The frequency spectrum gives in many cases a detailed information about the signal sources which cannot be obtained from the time signal. This permits many kind of diagnoses to be made. The frequency content can be found in many different ways, using scanning filter, filter banks or as it is the case mostly today a digital treatment of a record using Fourier Transformation.

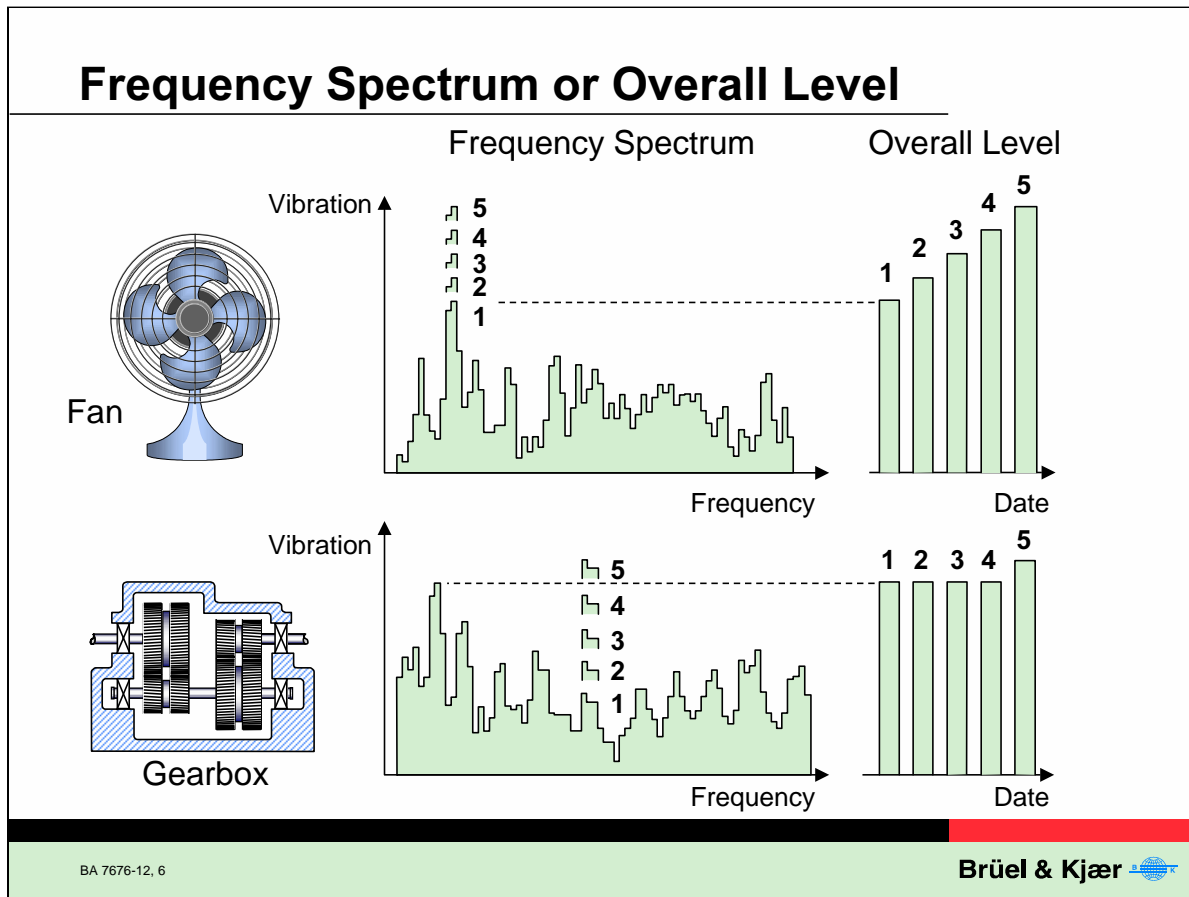

### Frequency Spectrum or Overall Level

To decide whether monitoring or testing of the overall level is sufficient or a complete frequency spectrum is required, the test engineer must know his machine and something about the most likely faults to occur or which part of the object is of interest.

The illustration shows two different situations in monitoring, but it might as well be testing:

**Monitoring of a fan:** The most likely fault to occur is unbalance, which will give an increase in the vibration level at the speed of rotation. This will normally also be the highest level in the spectrum. To see if unbalance is developing, it is therefore sufficient to measure the overall level at regular intervals. The overall level will reflect the increase just as well as the spectrum.

**Monitoring of a gearbox:** Damaged or worn gears will show up as an increase in the vibration level at the tooth meshing frequencies (shaft RPM number of teeth) and their harmonics. The levels at these frequencies are normally much lower than the highest level in the frequency spectrum, so it is necessary to use a full spectrum comparison to reveal a developing fault.

A general rule is overall measurements are permissible for simple, non critical machines, while more complex, more critical machinery requires spectral analysis.

## Presenting the Data

---

- Linear vs. Log Scaling
- Amplitude in dB?
- Linear and Logarithmic Frequency Scales
  - Decades
  - Octaves

### Presenting the Data

It is always important to put some effort into choosing the best way to present data.

The simplest is to choose linear scales with ranges dictated by the range of data, but often this does not permit important data to be clearly seen.

Therefore logarithmic scales are often used, sometimes for level using dBs or just with appropriate numbers at the tick marks, sometimes for the frequency maybe with decades or octaves as indications.

## Linear vs Logarithmic Scales

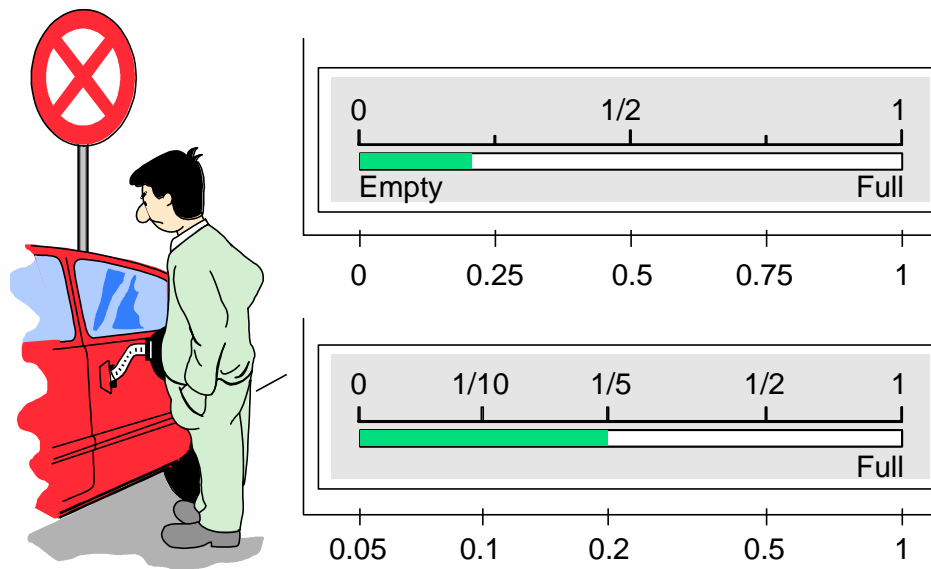

BA 7676-12, 8

Brüel & Kjær

### Scales

Let us forget vibration for a few minutes.

The situation shown here is well known to most people. Often it is difficult to judge the amount of petrol left in the car when the petrol gauge has a linear scale. If the petrol gauge had a logarithmic scale, the lower end of the scale would be “stretched” so that the amount of petrol left in the tank could be more easily seen. Note that the logarithmic scale has no zero.



## Linear vs Logarithmic Scales

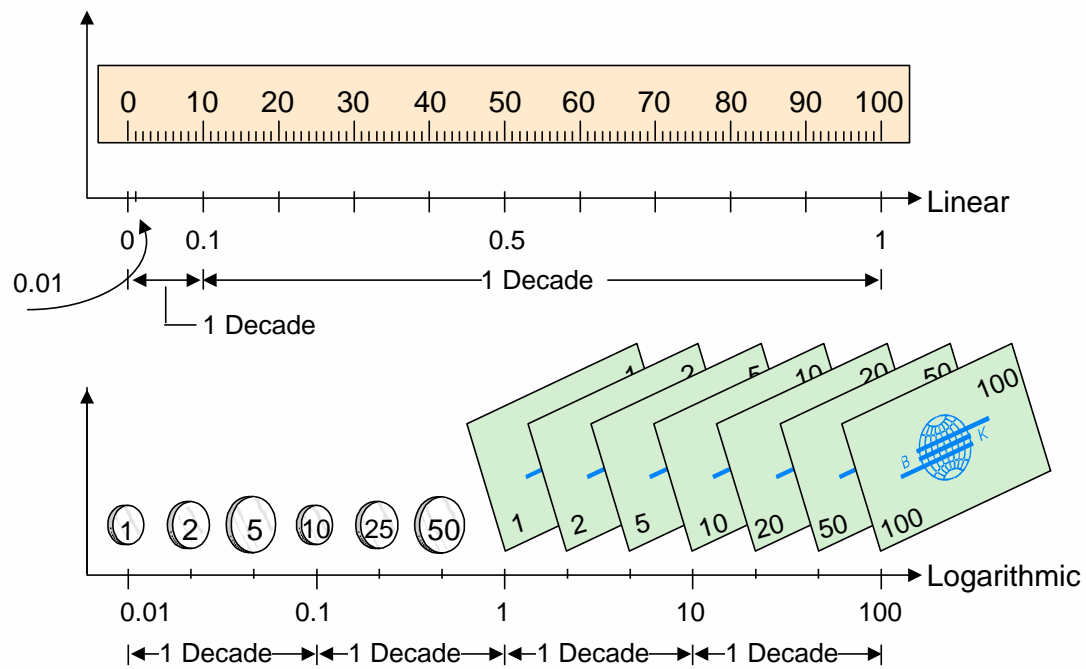

BA 7676-12, 9

Brüel & Kjær 

### Scales

Which scale to use depends on the unit to be scaled. Distance and time scales are typical examples of linear scales, but for scaling of units where the ratio between two values is of more interest than the absolute value it is an advantage to use logarithmic scales e.g. the different coins and notes in our monetary systems have values which, when plotted on a logarithmic scale, show approximately equal “distance” between adjacent values.

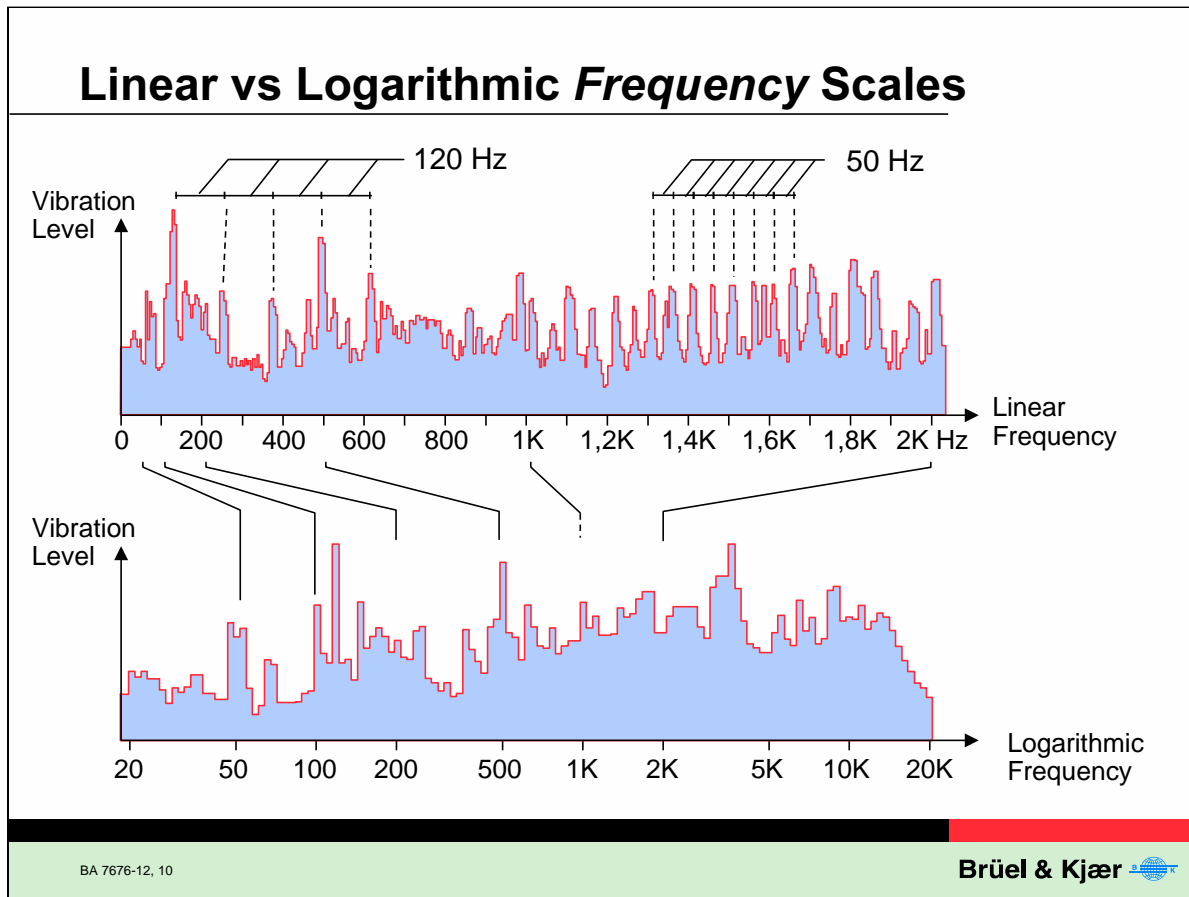

### Linear vs Logarithmic Frequency Scales

Both linear and logarithmic frequency scales are used in connection with vibration measurement. The linear frequency scale has the advantage that it is easy to identify harmonically related components in the signal. The logarithmic scale, however, has the advantage that a much wider frequency range can be covered in a reasonable space and each decade is given the same emphasis. The signal shown here is the vibration signal from a gearbox plotted with the two different scales. The harmonically related components in the signal are easily identified on the linear scale and the logarithmic scale gives many details in the low end while it covers a 10 times wider frequency range at the same time.

## Bandpass Filters and Bandwidth

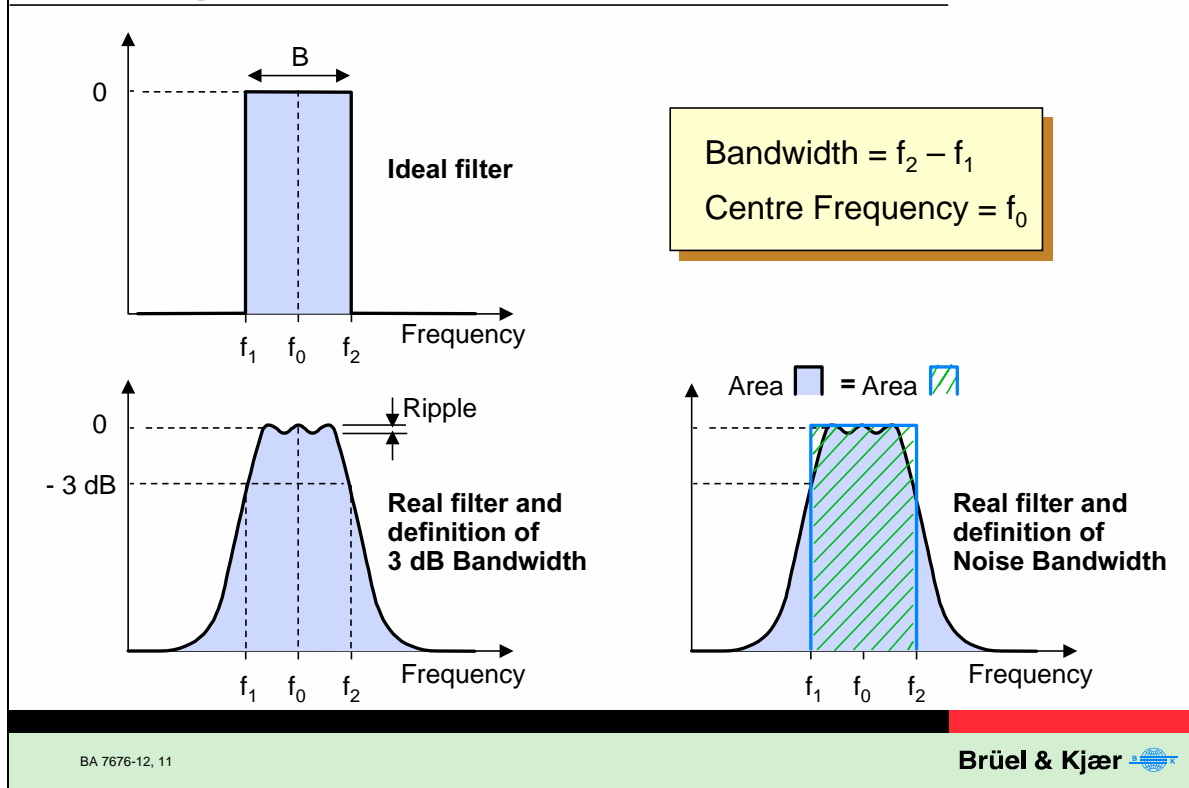

### Band Pass Filters and Bandwidth

Having chosen a frequency scale, the next step is to choose the form of the many individual filters which are used to make the analysis. This illustration shows the properties of an ideal filter and real filters.

An ideal band pass filter will only allow signals with frequencies within the pass band (bandwidth  $B = f_2 - f_1$ ) to pass. Ideal filters do not exist, however. In practical filters, signals with frequencies outside the passband will also go through, although in an attenuated form. The further away from the pass band, the more attenuated the signals will be. The bandwidth of practical filters can be specified in two different ways:

1. The 3dB (or half power) Bandwidth
2. The Effective Noise Bandwidth

The 3 dB bandwidth and the effective noise bandwidth are almost identical for most practical filters with good selectivity.

## Filter Types

### Constant Bandwidth

$$B = x \text{ Hz}$$

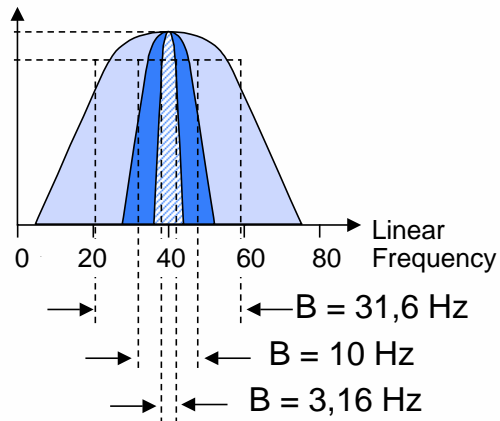

### Constant Percentage Bandwidth or Relative Bandwidth

$$B = y\% = \frac{y \times f_0}{100}$$

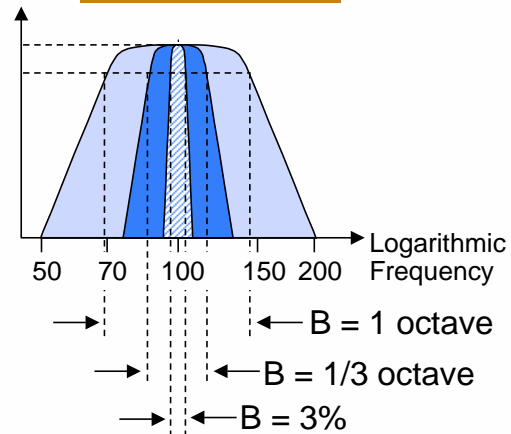

BA 7676-12, 12

Brüel & Kjær

## Types of Bandpass Filters

Two types of band pass filters are used for frequency analysis.

1. Constant Bandwidth filters where the bandwidth is constant and independent of the centre frequency of the filter.
2. Constant Percentage Bandwidth (CPB) filters, where the bandwidth is specified as a certain percentage of the centre frequency i.e. the bandwidth is increasing for an increase in centre frequency. CPB filters are some times called Relative Bandwidth filters.

## Constant Bandwidth Filtering

Bandwidth = 400 Hz

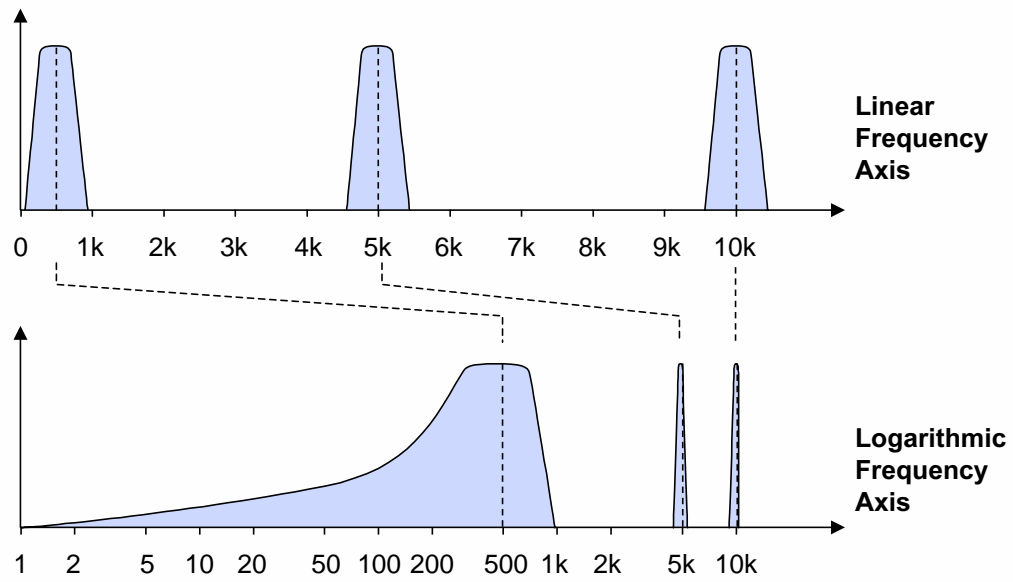

BA 7676-12, 13

Brüel & Kjær 

### Constant Bandwidth Filters and Linear Frequency Scales

When using constant bandwidth filters it is recommended to use linear frequency scales, when the result is to be displayed. See what happens if a logarithmic frequency scale is used!

## Constant Percentage Bandwidth Filters

Bandwidth = 1/1 octave = 70% of Centre Frequency

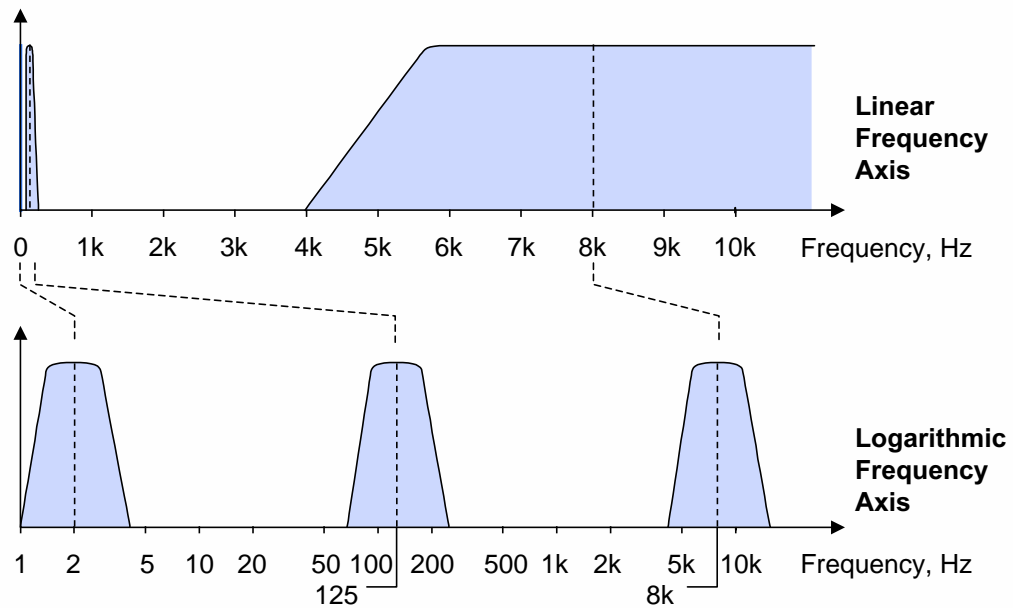

BA 7676-12, 14

Brüel & Kjær

### Constant Percentage Bandwidth Filters and Logarithmic Frequency Scales

When using constant percentage bandwidth filters it is recommended to use logarithmic frequency scales, when the result is to be displayed. See what happens if a linear frequency scale is used!

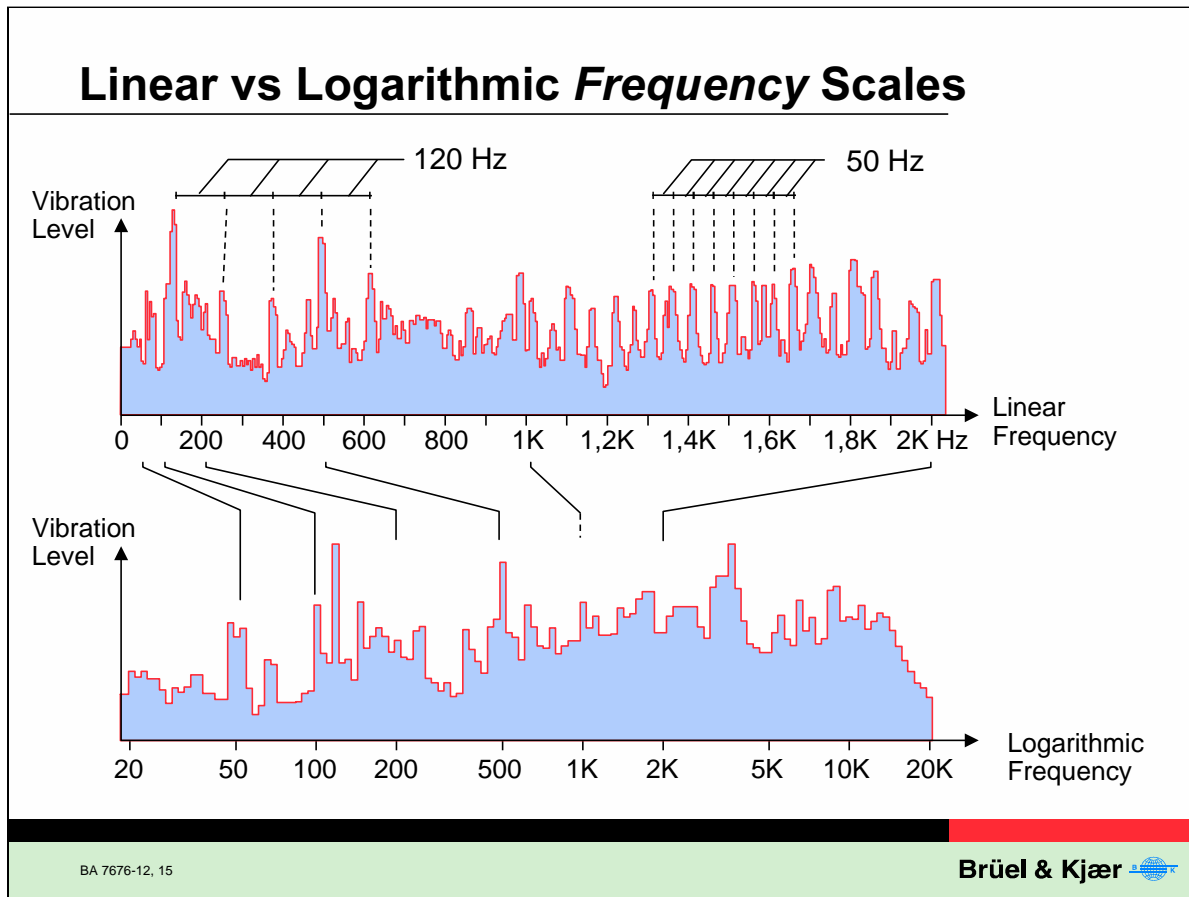

### Linear vs Logarithmic Frequency Scales

If the right combination of filter type and frequency scale is chosen, the frequency spectra look alike.

To know if the analysis is done with constant bandwidth filters or with CPB filters just have a look at the scaling of the frequency axis.

#### Which Type of Filter to Use?

Depends on the actual application.

*Rule of thumb:* Analysis with constant bandwidth filters (and linear scales) is mainly used in connection with vibration measurements, because signals from mechanical structures (especially machines) often contain harmonic series and sideband structures. These are most easily identified on a linear frequency scale.

Analysis with CPB filters (and logarithmic scales) is almost always used in connection with acoustic measurements, because it gives a fairly close approximation to how the human ear responds. In connection with vibration measurements, the CPB bandwidth filter is used for measurement of structural responses, and for survey of the condition of machines (3 decades can easily be covered by CPB bandwidth filters).

## Selecting Bandwidth

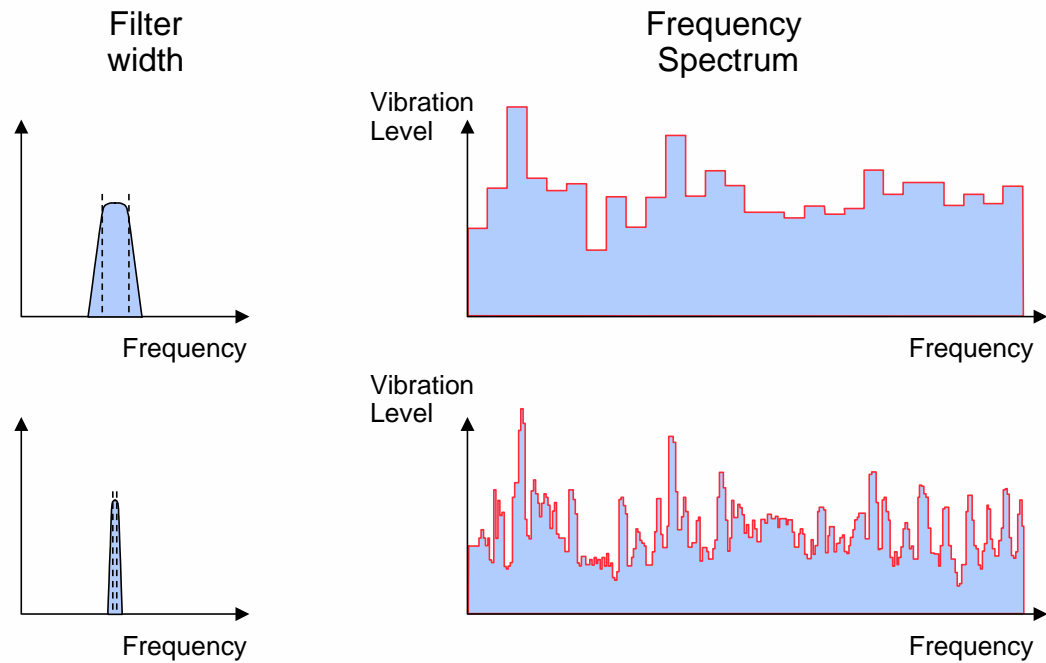

BA 7676-12, 16

Brüel & Kjær

### Selecting a bandwidth

The narrower the bandwidth used, the more detailed is the information obtained.

The filter bandwidth need to be selected in such a way that the important frequency components can be distinguished from one another. However it also has to be large enough to get the analysis done in a reasonable time.

The more detailed (narrow band) analysis however requires a longer analysis time.



## Most important in Frequency Analysis



B = bandwidth  
T = time

$$BT \geq 1$$

(often called the Uncertainty Principle)

### The BT Product

The statement  $BT \geq 1$  sometimes called the Uncertainty Principle, tells us that if we choose a very small bandwidth B, then we need a corresponding measurement time T which is very large, and there is no way around this basic principle. We can also explain it by saying that if we want to know whether there is a signal at 1 Hz (i.e. with a 1 second period) then we need at least to wait for one period of the signal before we can say much.

## Linear vs Logarithmic *Amplitude* Scales

### Advantages of logarithmic amplitude scale

- Constant factor changes are equally displayed for all levels
- Optimal way of displaying a large dynamic range

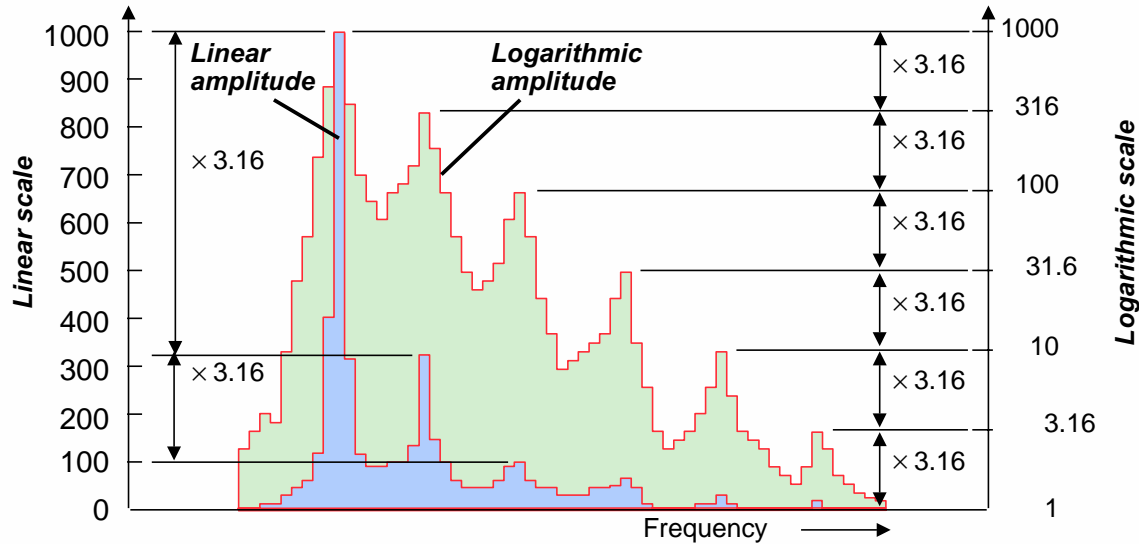

BA 7676-12, 18

Brüel & Kjær

### Linear and Logarithmic Amplitude Scales

It is often the case that interesting frequency components in a vibration spectrum have a much lower amplitude than the dominant components.

These low levels will hardly be registered if a linear amplitude scale is used. It is therefore common practice to use logarithmic amplitude scales. The logarithmic amplitude scale may be marked off in mechanical units, such as  $\text{ms}^{-2}$ , but often the decibel (dB) scale is used.

### Getting More Out of Data

An obvious consequence of the logarithmic amplitude scale is the chance to get the most out of existing data, since more can be seen at one time, without needing to change the display. This display also has the added advantage of compressing the effect of random fluctuations, both in machine vibration signal, and in noise.

## The dB Scale

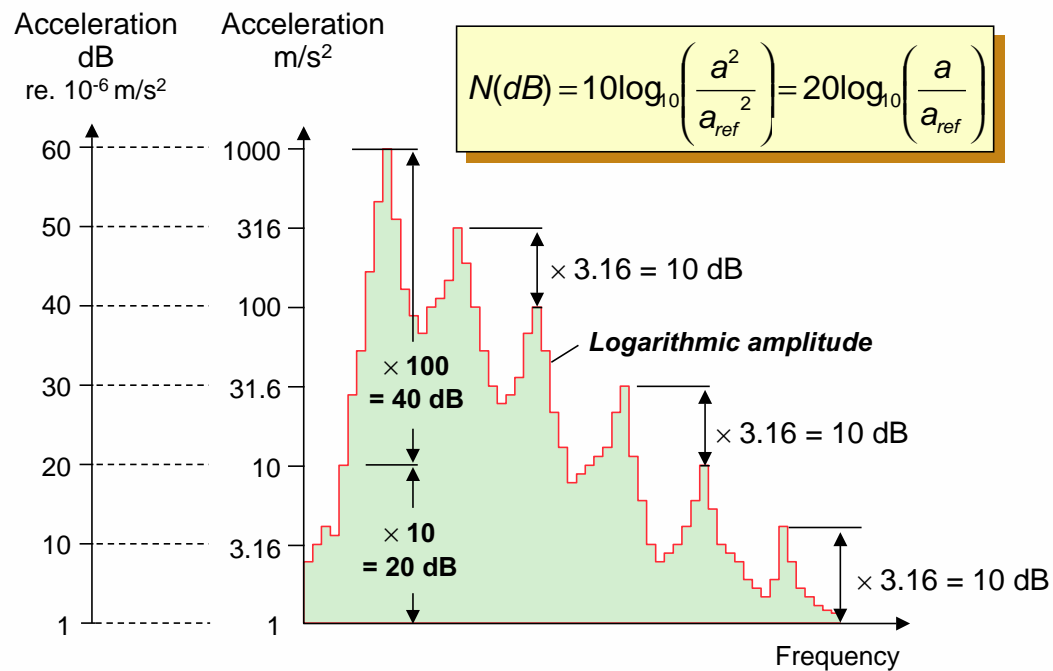

BA 7676-12, 19

Brüel & Kjær

### dB Scales

The dB scale reduces the considerable numerical span of the normal log scale to a compact linear numbering system. The dB scale is such that a given percentage interval in, say, acceleration level is represented by a given number of dB's. This is a great advantage when dealing with vibration signals, since we are often very interested in a percentage change in the vibration level rather than in the actual levels. Zero dB on the dB scale can be chosen for any vibration level e.g.  $1 \text{ ms}^{-2}$ . The level  $10^{-6} \text{ ms}^{-2}$  has, however, been internationally chosen as the reference level for acceleration. (Be careful however, some US and CDN military applications use  $10^{-6} \text{ g}$  as a reference!)

### The dB Formula

Conversion from actual level to dB or vice versa can easily be performed using this formula. The calculation can easily be carried out with a pocket calculator.

## Transmission of Vibration

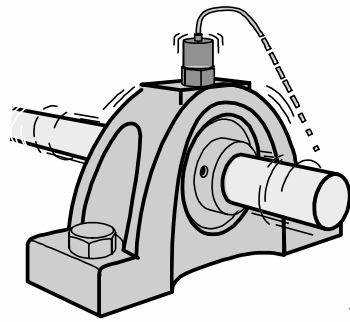

Input Forces + System Response (Mobility) = Vibration

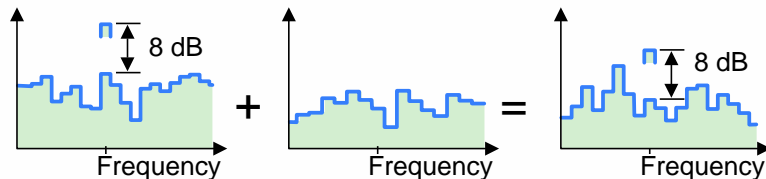

### Forces caused by

- Imbalance
- Shock
- Friction
- Acoustic

### Structural Parameters:

- Mass
- Stiffness
- Damping

### Vibration Parameters:

- Acceleration
- Velocity
- Displacement

BA 7676-12, 20 891875

Brüel & Kjær 

### Why a logarithmic Amplitude Scale?

Critical vibration components usually occur at low amplitudes compared to the rotational frequency vibration. These components are not revealed on a linear amplitude scale because low amplitudes are compressed at the bottom of the scale. But a logarithmic scale shows prominent vibration components equally well at any amplitude. Moreover, percent change in amplitude may be read directly as dB change. Therefore noise and vibration frequency analyses are usually plotted on a logarithmic amplitude scale.

What determines the magnitude of vibration?

What is creating the vibration?

It must be understood that when we measure vibration, it is often a compromise. We would much rather measure the forces generating the vibration directly. This is practically impossible. So we measure the result of the force, which is the vibration. The vibration spectrum, and even the overall level, is indirectly linked to the force spectrum, or overall level, via the mobility function. The diagram shows an interesting mobility phenomenon. The force spectrum contains a peak at the frequency shown. However, because the mobility has an “anti-resonance” at that same frequency, the vibration spectrum contains no significant peak at that frequency. This shows that it is not only the largest peaks in a spectrum that we should be interested in. But note that an 8 dB increase in force will still show as an 8 dB increase in vibration.

## “Real World” Vibration Levels

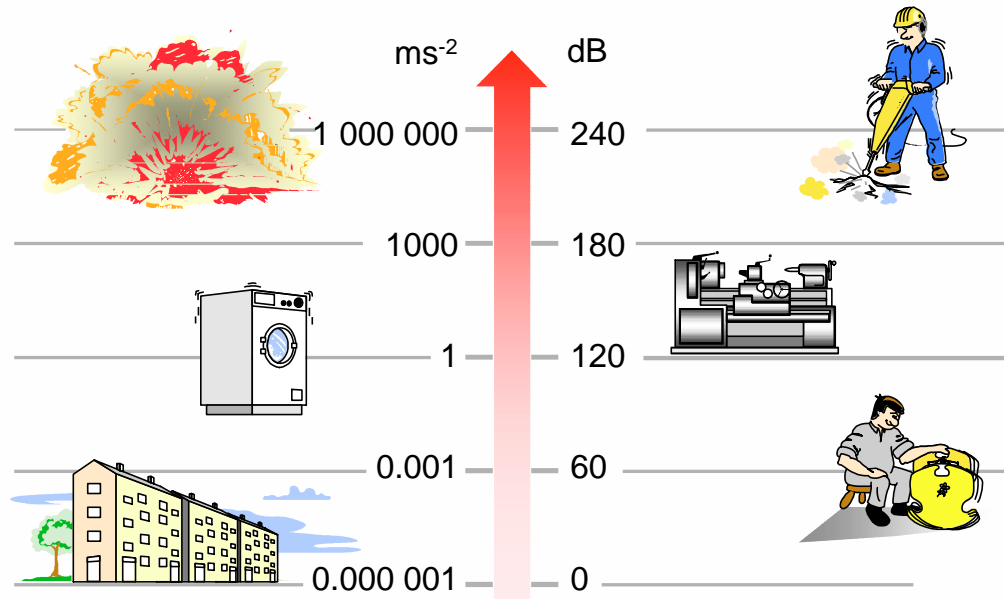

BA 7676-12, 21

Brüel & Kjær

### Actual Level Scales and dB Scales

With piezoelectric accelerometers we are able to detect a vibration amplitude range of almost 100 000 Million to 1 ( $10^{11}:1$ ); with a dB scale this range is reduced to a manageable 220 dB. The dynamic range of a single accelerometer will, however, typically be  $10^8$ .

## Vibration Parameters

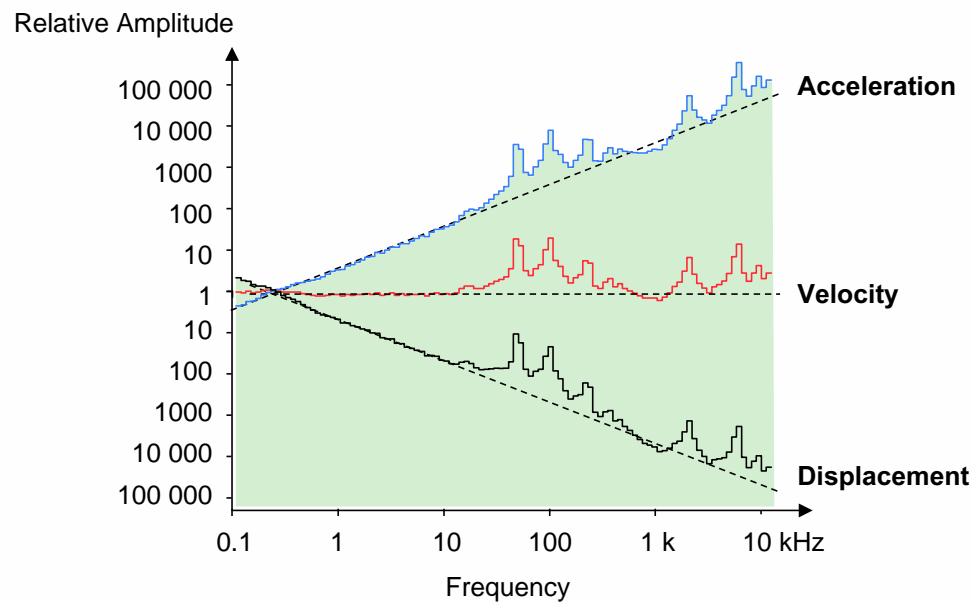

BA 7676-12, 22

Brüel & Kjær

### Which Parameter to Choose?

If the type of measurement being carried out does not call for a particular parameter to be measured e.g. due to some standard, the general rule is that the parameter giving the flattest response over the frequency range of interest should be chosen. This will give the biggest dynamic range of the whole measurement set up. If the frequency response is not known start by choosing velocity.

An advantage of the accelerometer is that its electrical output can be integrated to give velocity and displacement signals.

This is important since it is best to perform the analysis on the signal which has the flattest spectrum. If a spectrum is not reasonably flat, the contribution of components lying well below the mean level, will be less noticeable. In the case of overall measurements, smaller components might pass completely undetected.

## Which Parameter to Choose

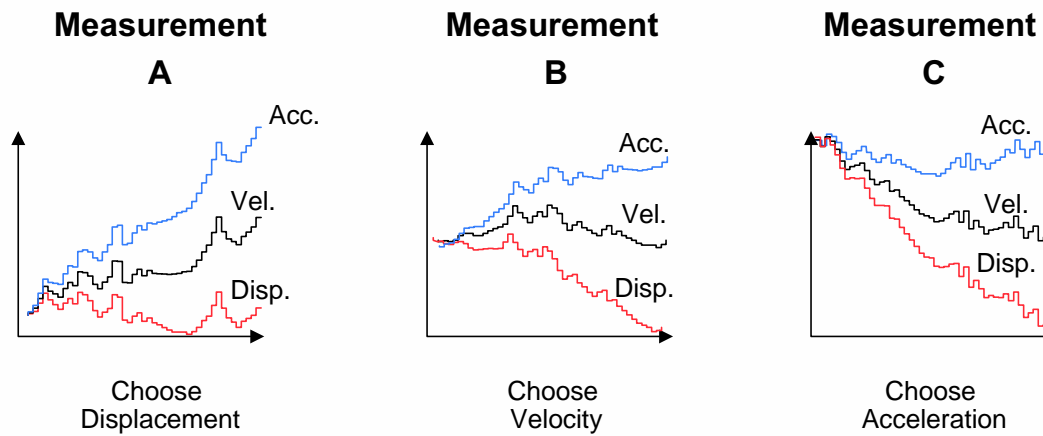

BA 7676-12, 23

Brüel & Kjær

### Use the Flattest Spectrum

In most cases this will mean that velocity is used as the detection parameter on machine measurements. On some occasions acceleration may also be suitable, although most machines will exhibit large vibration accelerations only at high frequencies. It is rare to find displacement spectra which are flat over a wide frequency range, since most machines will only exhibit large vibration displacements at low frequencies.

In the absence of frequency analysis instrumentation to initially check the spectra, it is safest to make velocity measurements (but still using the accelerometer, of course, since even the integrated accelerometer signal gives a better dynamic and frequency range than the velocity transducer signal).

## The Detector/Averager

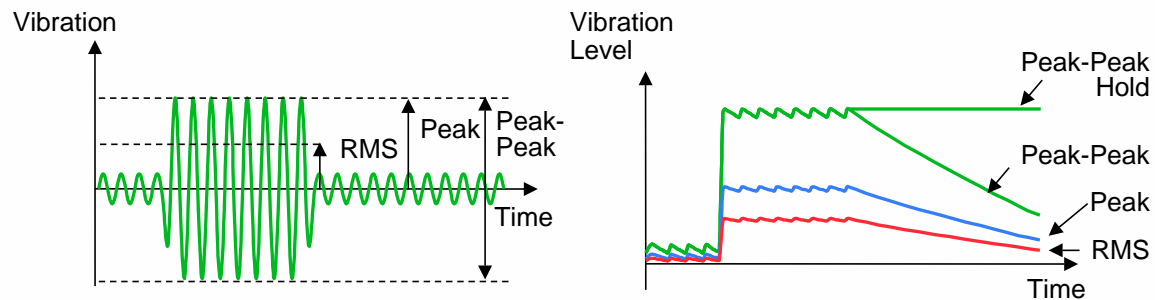
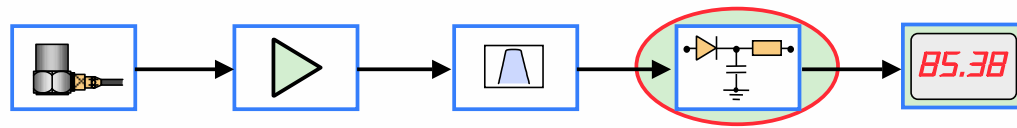

BA 7676-12, 24

Brüel & Kjær

### Detector/Averager

The final link in the measurement chain before the display is the Detector/Averager which converts the vibration signal into a level which can be shown on the display.

The example here shows the output level (RMS, Peak, Peak-Peak or max. Hold) for a burst of a sinusoidal signal of constant amplitude applied to the input.

Notice how the output level decays when the input level drops giving rise to fluctuations in the signal. The amount of fluctuation and decay is determined by the averaging time chosen.



## Averaging Time

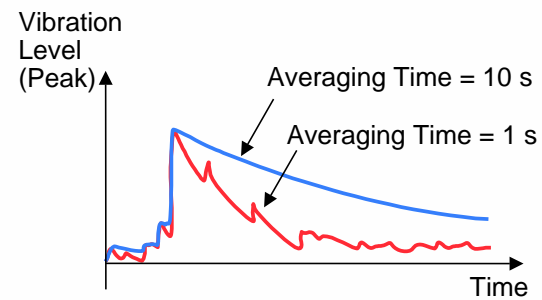
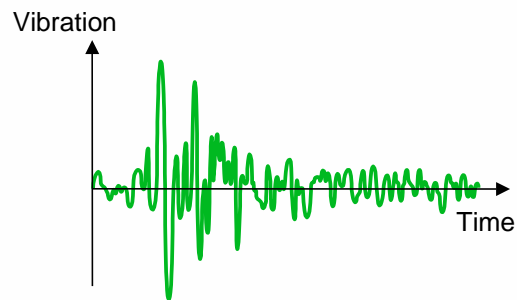
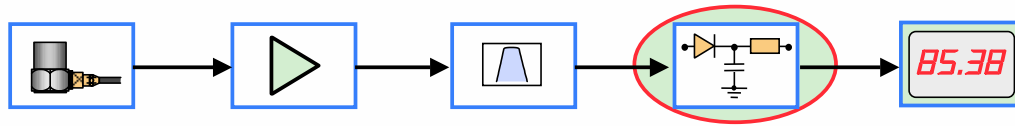

BA 7676-12, 25

Brüel & Kjær 

### Averaging Time

With a short averaging time the detector will follow the level of a varying signal very closely, in some cases making it difficult to read a result off the display. If a longer time constant is used however some information might be lost. This is especially true if the signal contains some impulses.

## Signal vs. System Analysis

Signal Analysis

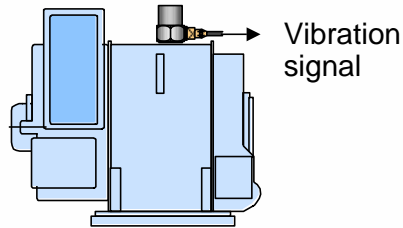

System Analysis

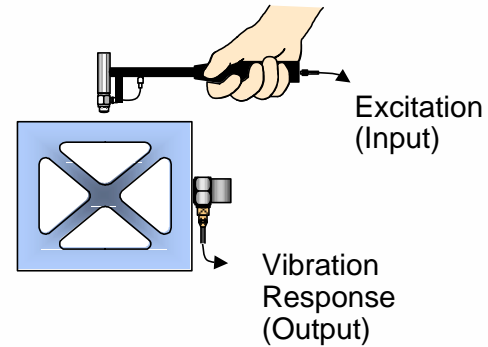

BA 7676-12, 26

Brüel & Kjær 

### System vs Signal analysis

In most of the preceding slides it has been assumed that a vibration existed, generated in some way by forces present in the system itself. When this vibration signal is analyzed we call it Signal Analysis.

During development of new structures, and in some cases to analyze in detail existing structures, it is a requirement to try to make a model of the structure, in such a way that if input forces are given the output vibration can be calculated.

The illustration shows such an application measuring the mobility by introducing forces at different positions and measuring the input force together with the output vibration. These types of measurements are used to make a modal model of the structure, which can then be used to predict the behaviour of the structure under given circumstances. The model can also be used to predict the effect of changes in the structure, especially if it is combined with Finite Element Modelling (FEM). This type of analysis is called System Analysis, but it is beyond the scope of this lecture to cover this in more detail.

## Conclusion

---

This lecture should provide you with sufficient information to:

- Choose the right vibration parameters to measure
- Present the measured data in a suitable way
- Understand the basic filter and analysis parameters and limitations
- Understand the difference between signal and system analysis

## Literature for Further Reading

---

- Shock and Vibration Handbook (Harris and Crede, McGraw-Hill 1976)
- Frequency Analysis (Brüel & Kjær Handbook BT 0007-11)
- Structural Testing Part 1 and 2  
(Brüel & Kjær Booklets BR 0458-12 and BR 0507-11)
- Brüel & Kjær Technical Review
  - No.2 - 1996 (BV 0049-11)
  - No.2 - 1995 (BV 0047-11)
  - No.2 - 1994 (BV 0045-11)
  - No.1 - 1994 (BV 0044-11)
  - No.1 - 1988 (BV 0033-11)
  - No.4 - 1987 (BV 0032-11)