

First Edition
2010

Copyright © 2010 Esa T. Meriläinen
All rights reserved

Homepage: www.current-drive.info

ISBN: 1450544002
EAN-13: 9781450544009

Published in the U.S.A. through a print-on-demand service

While every precaution has been taken to ensure the accuracy of information presented herein, the author and publisher assume no responsibility for errors or omissions. Nor is any liability assumed for any possible damages or losses arising from the use of this information.

1

SOME PARALLELS

1.1 The Era of Direct Current

The issue whether loudspeakers should be excited by a voltage or current signal is quite well comparable to a dispute that took place over a century ago, concerning whether the production and distribution of electricity should operate on direct or alternating current.

Thomas A. Edison had opened, in New York, the world's first power generating plant, that supplied a DC voltage of 110 volts for an area of a few square kilometres in Manhattan. Another pioneer of electrical technology, Croatian-born Nikola Tesla, instead, believed strongly in the superiority of the three-phase AC system he had developed. In 1886, George Westinghouse founded an electric company to utilize the inventions and patents of Tesla and to compete with Edison.

Edison was not at all pleased seeing a rivaling system threatening his dominating stature in power production. The conflict caused a breach between Edison and Tesla, and a public struggle about which system would become prevalent. Edison even resorted to a trick campaign in his attempt to defame AC power, that he thought was dangerous.

The technical superiority of AC became, however, soon apparent to the public, and the power plant built at Niagara Falls in 1895 denoted a breakthrough for AC technology although DC systems were still used in cities for a couple of decades.

This story teaches how even top-talented persons may, blinded by their own human limitations, strive to advocate technical solutions that are ineffective and anything but optimal in fulfilling their purpose.

How would things have turned out without the innovations brought

by Nikola Tesla? Would somebody else have filled his place and turned the unfavorable direction of development? Or, would it be that even this day our wall sockets would supply direct current and conversion of one voltage for another would only be possible by chopper techniques?

Reason thus prevailed in power technology, and this is also possible to happen in audio technology, for moving to current-drive does not even require new investments from the industry, only a little reformative thinking.

1.2 Modulation Methods

The difference between loudspeaker driving methods is, by its quality and significance, also comparable to the difference of the methods used for modulating radio waves.

In amplitude modulation (AM), that has been in use since the '20s, the amplitude of the carrier wave is modified in accordance with the transmitted signal. Unfortunately though, many interfering factors along the way also tend to modulate the same amplitude, so the sound quality of the received transmission is quite poorly controlled.

Instead, in frequency modulation (FM), developed in 1928 by Edwin H. Armstrong, the transmitted signal is used to modify the carrier frequency, which is much less affected by climatic and technical disturbances than is the amplitude. The message is thus recovered with better quality since, in the transmission chain, there is not used such quantities, or conversions between quantities, that are subject to uncontrolled factors.

Correspondingly, by operating a speaker driver directly by a current signal, one can avoid the interference mechanisms pertaining to the relationship between voltage and current. After experience, it is not so overstated to assert that the difference in sound quality between current- and voltage-driven speakers is of the same order than the quality difference between AM and FM broadcasts in normal receiving conditions (ignoring the stereophony of FM broadcasts and the present, very lamentable practice to compress transmissions into unnatural growling).

1.3 Deflection Coils

A tangible example of the improvement brought by current-drive is found in TV technology.

In the past, it was customary to drive the vertical deflection coils of picture tubes by voltage, in a like manner that loudspeakers are still driven today. As a consequence, when the coils warmed up and their resistance increased, the amplitude of the deflection current altered, causing changes in picture size. Even thermistors had to be employed when trying to compensate these temperature effects.

Later on, these coils were learned to be operated directly by current, so that the changes in load impedance were no more able to affect the strength of the deflection field, and the picture kept more stable.

Thermal compression is also a familiar phenomenon in loudspeaker technology. In voltage-driven speakers, the variations in sound level and frequency response, caused by voice coil heating, are a significant problem, especially in high-power systems. One might expect this alone to be a sufficient reason to try out the possibilities offered by current-drive; but, for some reason, the required change in the mindset has not yet at all reached the designers of the audio field.

3

OPERATION OF THE ELECTRO-DYNAMIC TRANSDUCER

Overwhelmingly the most popular means of converting electrical signals to sound is still the electro-dynamic principle, wherein movement of the vibrating diaphragm is accomplished by interaction between current and a magnetic field. Taking into account the enormous amount of this kind of speaker drivers, all over the world, and their significance in our daily life as producers and modifiers of sound, there is a need to have a little deeper than usual overview into the physics of operation of these basic necessities. Thereby we acquire requisites for understanding the interference mechanisms acting in a driver and are able to dispel some erroneous notions, that one often sees presented.

Here, we consider moving-coil drive units whose diaphragm is structurally rigid. The electro-dynamic principle is also used in less common, mostly for high frequencies intended ribbon and planar-diaphragm devices, but the properties of these differ considerably from the former.

3.1 Magnetic Force Effects

Figure 3.1 shows magnet assemblies commonly used today in speaker drive units. The magnet itself (stamped by grey) is usually of ferrite material and ring-shaped. To this is glued fast steel pole pieces, that direct the magnetic flux to flow through the air gap as effectively as possible. In quality drivers, a T-shaped center pole is sometimes employed (Fig. b), providing more symmetric flux distribution than in the Fig. 'a' case.

By using more effective and more expensive materials than ferrite, the magnet itself can be made smaller, enabling it to be positioned in the

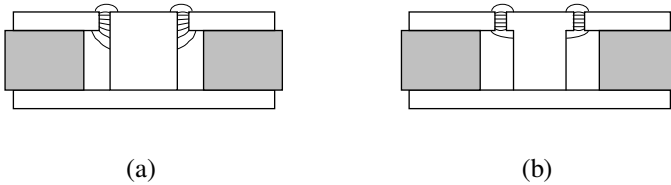

Figure 3.1. Cross-sections of common magnet assemblies. a) Typical shape of pole pieces in inexpensive ferrite magnet drive units. Magnetic flux in the air gap is not symmetric. b) Better solution, that employs a T-shaped pole piece.

middle of the assembly. The stray field is thereby lesser, and the flux doesn't have to go through a hole in the magnet; a thing which it naturally won't do. The mechanisms pertaining to the operation itself are nevertheless the same, irrespective of the structural details.

The drive force F acting upon the voice coil in the air gap is obtained from the well-known basic formula:

$$F = B l i \quad (3.1)$$

B is the magnetic flux density (in Teslas) acting perpendicular to the wire, l is the length of wire contained within the magnetic field, and i is the current in the wire. B is the flux density that exists when the current is zero. The current always causes its own magnetic field, that may react with adjacent iron, but the effect does not relate to equation (3.1). (So-called flux modulation is thus not evil per se but a necessary part of the force generation.)

The constants B and l generally always appear together, and their product is referred to as the force factor, whose unit becomes N/A or Tm.

When examining equation (3.1), the attention should focus on a very important fact regarding control of the voice coil: namely, the voltage between the ends of the wire does not appear in this equation at all. To this, then, pertains our first cause of wonderment:

The drive force actuating the voice coil is determined by the current flowing in the coil. Instead, the voltage across the coil does not even affect straightly the development of the force. Even for this reason, it is ill justified and downright amazing that everywhere it is taken as self-evident that an amplifier has to feed loudspeaker terminals by a voltage signal without

any respect to current.

If the driver impedance were a mere pure, constant-staying resistance, then, and only then, would it be all the same whether the driver were fed by voltage or current since these two would at every moment be directly proportional to each other. If the impedance were even linear and interference-free, then still voltage drive would defend its status since the differences between these two driving modes would be mostly related to frequency response shaping. In reality, however, the driver impedance is, as will be demonstrated later, everything but interference-free and linear, and hence, only by acting directly on current, can it be guaranteed that the force actuating the voice coil corresponds to the driving signal as accurately as possible.

Even without special knowledge on the behavior of impedance, the discrepancy between equation (3.1) and contemporary audio amplifier technology should ring some alarm bell within the inward parts of every intellectually honest individual interested in electrical engineering. Or, at least, this shortcoming should make pertinent people seriously call into question those inducements by which the present, physical rationales ignoring practice has gained its justification.

The analogue signal obtained from program sources, like e.g. CD players, is always a voltage signal, and there is nothing inappropriate in it. Signal processing in the front stages of amplifiers is also practical to be performed in voltage mode since using current signals in this context wouldn't provide any advantage. Hence:

In order to put the voice coil into motion, *somewhere* in the signal path must occur a conversion from a voltage signal to a current signal. The contemporary practice is exclusively that this pivotal conversion is left solely as the responsibility of the speaker driver. In the driver, however, the conversion always occurs *uncontrolled*, various electromotive forces being heavily involved in the development of impedance. Instead, when performed in the amplifier, this conversion can be carried out *controlled*, providing the speaker with direct drive, instead of indirect one.

Irrespective of where the deepest reasons for the continuation of the current unnatural tradition might be, to one who has somewhere listened an ordinary hifi set of say 10 000 currency units and compared this with a do-it-yourself set utilizing current-drive and costing a small fraction of the former, the difference in favor of the latter is so unambiguous that

to proceed a big part of its way in the air, so, in practice, the solenoid force fortunately stays much smaller than the actual drive force. Nevertheless, the solenoid force is a significant cause of 2nd-harmonic distortion.

Figure 3.2c depicts the flux brought about by the magnet and voice coil together. In the vicinity of the voice coil, the flux lines are strained downward, so the drive force acts in this case upward. The flux touring through the bottom is now slightly weaker than in case 'a'.

The application of current-drive does not affect the magnitude of the solenoid force itself, but in the elimination of the adverse effects of flux modulation and the inductance relating to it, the driving method has a very essential import.

The solenoid force can, however, be significantly reduced by using, in the magnetic circuit, materials that are good electrical conductors. Some manufacturers have used a shorting ring around the center pole, as shown in Fig. 3.2d. The ring corresponds, in operation, to a short-circuited secondary winding of a transformer.

When the secondary of a transformer is loaded by some impedance, this impedance is seen on the primary side, in principle, multiplied by the square of the turns ratio. Hence, in this case, a resistive load is established in parallel with the inductance of the primary winding (i.e. voice coil), shorting part of the inductance's current. Thereby, the voice-coil-induced flux and the solenoid force associated with it reduce, although the inductance in itself does not decrease. The same advantage is also gained by using well-conducting magnet material, like neodymium, whose eddy currents effect a similar loading.

Irrespective of other structural details, it is usually worth striving for strong magnetic flux in the air gap since thereby one not only improves sensitivity and efficiency but also decreases the relative significance of the solenoid force.

3.2 Motional Equations under Current-Drive

It is easy to think that in the ideal case the displacement of a loud-speaker diaphragm should follow accurately the applied signal. In reality, however, it is not so and ought not to be since the instantaneous value of the acoustic pressure developed is not due to the diaphragm position. In the following, we will thus consider how the motion of the diaphragm is actually determined, assuming it is rigid and the operation of the system is linear.

Figure 3.3a shows a cross-section of a typical cone driver in a closed cabinet. The moving portion of the driver consists of the cone, the voice coil with its former that actuates the cone, and the dust protection cap. The suspensions of the cone may also be partially included in the moving mass, into which in practice also integrates a bit of the surrounding air.

The duty of the suspensions is to allow motion in the direction of the axis and, at the same time, prevent traverse motion; and they constitute a spring that tends to return the diaphragm to its rest position. In closed enclosure, the driver diaphragm is also loaded at low frequencies by the air spring of the enclosure. Manufacturers generally specify for their drivers the equivalent volume, with which the spring force caused by the enclosure equals the spring force of the cone suspensions.

Besides the mass and the springs, the mobility of the diaphragm is also affected by a third factor, mechanical resistance, that tends to slow down movement. This effect develops because the deformations taking place in the suspensions require energy, and this manifests as a counter-force proportional to the velocity of the diaphragm. Some retardation is

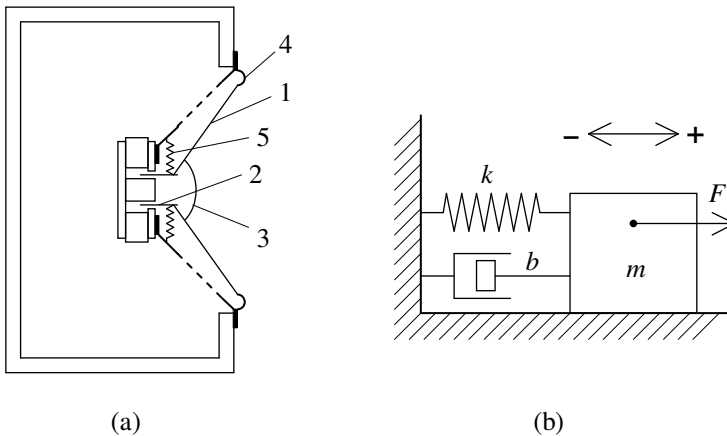

Figure 3.3. a) Cone driver in closed enclosure. The diaphragm (1), voice coil former (2) attached to it, and dust cap (3) are able to move, hanged on the outer suspension (4) and inner suspension (5). The outer suspension is, in hifi speakers, usually of rubber, and the inner one is usually of folded and stiffened cloth. The air compressed between the dust cap and the magnetic pole is always led out via some route. b) Mechanical model corresponding to the speaker of Fig. 'a'. The mass piece is assumed to move on its track without friction. In addition to the mass inertia, the system's operation is governed by the spring constant k and damping constant b .

also caused by air flows in the interior structures of the driver and in the damping material used in the enclosure.

On these grounds, we may construct for the driver the mechanical model shown in Fig. 3.3b. The force F , produced by the voice coil, acts upon a sliding object that has mass m and that is attached to a spring and a damper. The spring constant k includes the effects of all springs. The mechanical resistance is represented by the damping constant b .

The force F becomes therefore divided into three components, which are:

- force that accelerates the mass, ma , where a is the acceleration
- force that stretches the spring, kx , where x is the displacement from the rest position
- force that moves the damper, bv , where v is the velocity

The positive direction of all motion-describing quantities has been defined as the same (in Fig. 3.3b, to the right). Hence, we may write:

$$F = ma + bv + kx \quad (3.2)$$

Since velocity is the time derivative of distance and acceleration is, in turn, the time derivative of velocity, we further obtain, recalling formula (3.1):

$$m \frac{d^2 x}{dt^2} + b \frac{dx}{dt} + kx = Bli \quad (3.3)$$

which describes in a differential equation the dependency between displacement x and applied current i .

The transfer function corresponding to equation (3.3) can now be directly written, according to the principles explained in appendix sections B4 and B5:

$$\begin{aligned} \frac{X}{I} &= \frac{Bl}{ms^2 + bs + k} \\ &= \frac{Bl/m}{s^2 + \frac{b}{m}s + \frac{k}{m}} \end{aligned} \quad (3.4)$$

where X and I are interpreted as phasors. The result is a 2nd-order low-

At frequencies distinctly higher than ω_0 , i.e. in the normal operation band of the speaker, the displacement decreases inversely proportional to the square of frequency, the dominant counter-force being due to the mass. It is perhaps a little surprising that, in this region, the displacement of the diaphragm is about in opposite phase with respect to the current. In other words, at the moment when the current applied to the plus-terminal of the driver reaches a positive peak, the diaphragm is in its rearmost position.

At the resonant frequency, the counter-forces caused by the spring and mass cancel out each other, and we are left only with the damper, that has a conclusive effect on the Q value.

Above, we have mostly discussed about cone drivers, but the equations presented also hold as such for dome-type high-frequency units. These differ structurally from that in Fig. 3.3a mainly in that the cone and outer suspension have been removed, and a dome of the same width as the voice coil acts as the diaphragm. Also, high-frequency drivers (tweeters) are always sealed from the back, so that pressure variations generated by the bass driver (woofer) wouldn't mess up the operation.

The mechanism shown in Fig. 3.3b is common also elsewhere than in loudspeakers, for a corresponding model applies, for instance, to the suspension of a car wheel. The wheel with its drum establishes a mass that is able to move attached to a spring and a shock absorber. The duty of the shock absorber, or damper, is here to lower the Q value to a reasonable level, so that the system doesn't exhibit resonance on a bumpy road.

3.3 Effect of Motional EMF

Loudspeaker drive units are usually assigned a nominal impedance (usually 4, 6, or 8 Ω), which provides, in practice, only a kind of average value of the actual impedance in the frequency region of interest. When measuring the DC resistance, the result obtained is usually about 75% of this nominal value. On the other hand, at the high and low extremes of the frequency range, the impedance can be many times higher than the nominal value. The reason for this are the two kinds of electromotive forces (EMF) induced in the voice coil: the motional EMF caused by the motion of the coil and the inductive EMF caused by the inductance of the coil.

Electromotive "forces" are voltages, by nature, although they are called forces. They can be represented, in the circuit, by built-in voltage

sources, whose effects can be examined externally by measurement. Motional EMF is utilized, for example, in electro-dynamic microphones.

Electromotive forces always appear in series with the wire's resistance, so we may use, for the driver, an equivalent circuit shown in Fig. 3.4. The coil's DC resistance has been designated by R_c and the inductance by L_c . The inductive EMF is represented by voltage e_i . R_p represents the loading the eddy current and hysteresis losses introduce upon the inductance. R_p is not constant but increases with frequency.

Voltage source e_m represents the motional EMF, which can always be calculated from the formula:

$$e_m = B l v \quad (3.7)$$

The motional EMF induced in the circuit is thus directly proportional to the velocity of the voice coil, v . Also here, B is the flux density the wire sees when no current is flowing. All EMF due to the current-induced flux is contained in e_i .

Electromotive forces by nature strive to oppose the factor that originally caused them. Consequently, both e_m and e_i have such polarity that they tend to reduce voice coil current, increasing accordingly the total impedance.

According to a very common conviction, the motional EMF (also called back EMF) of the driver should somehow be suppressed or eliminated by keeping the output impedance (or resistance) of the amplifier low, so that the amplifier acts as an ideal voltage source. The truth is, however, that motional EMF can by no means be suppressed into non-existence or oblivion since law (3.7) can never cease to be valid and the relative proportion of EMF in the voltage across the driver can never be

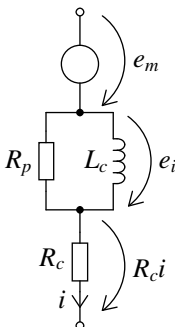

Figure 3.4. Electrical equivalent circuit of a speaker driver. The terminal voltage can always be divided into three components, which are: resistive voltage drop $R_c i$, inductive EMF e_i , and motional EMF e_m . Due to the electromotive forces, the driver's impedance magnitude is always greater than the mere DC resistance.

reduced, no matter what kind of output impedance is used. To the same pseudo-scientific illusory thinking, upon which the ascendancy of voltage drive in fact largely rests, also belongs a fiction that an output impedance as low as possible, relative to the driver impedance, "controls" the speaker and hence as though prevents extraneous oscillations.

According to equation (3.7), e_m is always present when the voice coil is in motion, irrespective of the cause of this motion. In a loudspeaker, the motion is due to the drive force, that in turn, is directly proportional to the current, as described by equation (3.1). In phasor form, it may hence be written: $E_m = Z_m I$ where Z_m is the electrical impedance (motional impedance) caused by the motional EMF. The appearance of the back EMF, therefore, does not in any way depend on e.g. whether a signal is starting or stopping or whether the diaphragm is returning toward the rest position or in which direction power is instantaneously flowing between the amplifier and speaker.

The model of Fig. 3.4 thus constitutes a linear impedance consisting of three internal components, whose relative magnitudes, at a given frequency, depend only on the driver's own parameters and the enclosure but not on external circuitry.

The amplifier sees the speaker driver always as a mere impedance load, that also incorporates the motional impedance. The motional EMF is thus always present as one voltage component in the closed circuit formed by the amplifier's output and the driver. Hence, this so-called back EMF by no means loses its significance when the amplifier's output impedance is low, but inevitably acts as an essential factor in the driver's voltage, as shown in Fig. 3.4, as long as the voice coil moves at all.

Moreover, when the system is linear, *all* effects of the motional EMF are incorporated in the motional impedance Z_m , and besides it, the motional EMF does not have any own, separate impact on the transient properties, that are often sought to be "controlled" by minimizing the output impedance. The transient reproduction properties of a linear system are completely determined by the frequency response properties through the Fourier transform, as presented in appendix section C4. Consequently, if the changing of some parameter (like e.g. the output impedance) doesn't have any apparent effect on the frequency response, the transient performance cannot change either.

$$|Z_m| = \frac{(Bl)^2}{m} \cdot \frac{\omega}{\sqrt{\left(\frac{k}{m} - \omega^2\right)^2 + \left(\frac{b\omega}{m}\right)^2}} \quad (3.9)$$

We take as an example a typical, moderately small, unenclosed bass-midrange driver for which $Bl = 6 \text{ Tm}$, $m = 0.008 \text{ kg}$, $k = 1000 \text{ N/m}$, and $b = 1.5 \text{ Ns/m}$. These values yield a resonant frequency of 56 Hz and a mechanical Q value of 1.9. A curve of the absolute value of the motional impedance is shown in Fig. 3.5, also featuring a typical magnitude of voice coil resistance (6Ω).

In the region of the resonant frequency, $|Z_m|$ is many times higher than the DC resistance R_c and becomes equal only at 140 Hz. At frequencies higher than this, $|Z_m|$ is about inversely proportional to frequency, so that still at 2 kHz, $|Z_m|$ is 6% of R_c . Hence:

Figure 3.5 proves erroneous such a view that motional EMF would only have impact in the resonance region and would be negligibly small at higher frequencies. Although the magnitude of the motional impedance is far from the resonance point less than the DC resistance, the motional impedance has, ne-

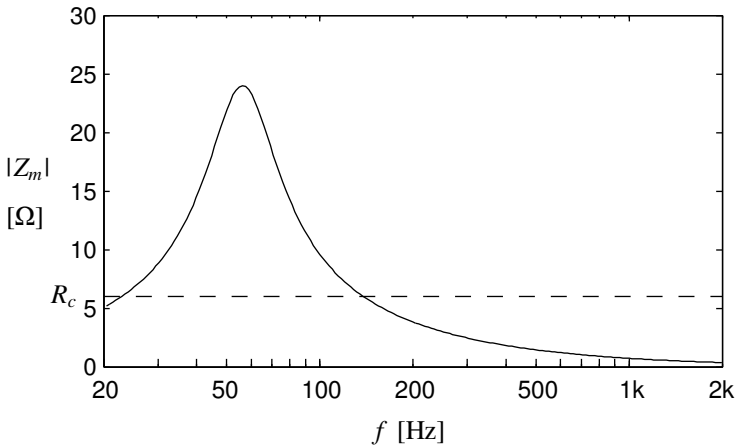

Figure 3.5. Magnitude plot of the motional impedance of an ordinary hifi driver with approx. 5-inch diameter. The dashed line, set at 6Ω level, represents, for comparison, typical voice coil resistance. The motional impedance is not negligible even at the upper end of the operation band.

vertheless, yet very essential significance through the whole mid-frequency range.

When measuring the total impedance of a driver, this feature does not easily show up due to phase differences between the various components.

Moreover, the example driver described does not represent, in this regard, any worst case. According to equation (3.9), $|Z_m|$ is proportional to the square of the force factor Bl . When using higher force factors, as is customary when desiring high sensitivity, the motional impedance can be a lot higher than in Fig. 3.5. For example, an increase of 3 dB in the force factor already effects the doubling of $|Z_m|$.

When the driver is mounted in a closed cabinet, the spring constant k increases, effecting increase in ω_0 and Q , according to equations (3.5) and (3.6). Then, also the peak of the motional impedance moves to a higher frequency, increasing further the proportion of $|Z_m|$, especially in the lower mid-frequency range. In bass reflex enclosures, the motional impedance has, in turn, two peak points, of which the higher is usually near 100 Hz.

In high-frequency drivers, the effect of motional EMF is also strong although no attention is generally paid to it. The resonant frequency is usually of the order of 1 kHz, and the force factor is typically about 3 Tm while the moving mass is some 0.3 g.

Far above the resonant frequency, the motional impedance is nearly independent of k and b . Equation (3.8) then simplifies to the form:

$$Z_m \approx \frac{(Bl)^2}{j\omega m}, \quad \omega \gg \omega_0 \quad (3.10)$$

By using the values mentioned, the magnitude of the motional impedance of a tweeter is found to be e.g. at 4 kHz still as high as 1.2 Ω . The value is, in its order of magnitude, everything but such that could be flat ignored when sound quality is of any concern.

3.4 Inductive EMF

All EMF inducing in the voice coil can be considered being due to Faraday's law of induction, which states that the EMF generated in each coil loop equals the rate of change of the magnetic flux passing through the loop. So, the difference between motional EMF and inductive EMF

is, in fact, only in the reason for which the flux changes.

In the case of motional EMF, this flux alternation stems from the fact that, as the loop moves, greater or lesser part of the permanent magnet's flux tours through the loop (see Fig. 3.2a). In the case of inductive EMF, in turn, the flux of the loop alternates as a consequence of alternation in the coil's current (Fig. 3.2b). As long as the operation is linear, these two mechanisms act independent of each other, according to the superposition principle.

Due to loss mechanisms arising in iron, the inductive EMF (e_i in Fig. 3.4) cannot be easily described by equations. Driver manufacturers generally specify some value for the voice coil inductance, but based on this, not much can be deduced about the behavior of the inductive EMF and the impedance due to it. The reason is in the eddy current losses, whose relative proportion in the total power losses strongly increases as frequency rises. The phenomenon of hysteresis, inherent in the magnetization of iron, also has its effect on the resistive loading that appears in parallel with the inductance (L_c in Fig. 3.4), since overcoming hysteresis requires work too. Both loss factors manifest through the transformer action described in section 3.1.

Inductance depends on coil structure in the following way:

$$L_c = \frac{N^2}{R_m} \quad (3.11)$$

where N is the number of turns and R_m is the reluctance, or magnetic resistance, seen by the flux. R_m opposes the flow of flux correspondingly as electrical resistance opposes the flow of current.

Relation (3.11) is valid for all kinds of coils, but its significance in this context is mostly advisory. Inductance depends on the square of the number of turns and how easily the flux of the voice coil is able to flow. Most part of the reluctance accrues inside the coil where the flux flows relatively narrowly. So inductance is, in principle, directly proportional to the cross-sectional area of the coil.

Figure 3.6 shows measurement results of the magnitude of the inductive impedance in a 6.5-inch woofer and in a one-inch tweeter unit. In order to prevent motional impedance from marring the measurement, the voice coils were fixed, with epoxy glue, firmly to the pole pieces. The results have been obtained by applying the conventional impedance measurement method, by measuring the voltage difference between the driver and a resistor equal in value with the voice coil resistance, the current being equal for both. Thereby, we are left with the mere induc-

even on the bass alignment. Whether the driver is 4- or 8-ohmic, is quite irrelevant in this regard because the ratio of inductance and resistance is, in practice, quite independent of the rated impedance.

3.5 Total Impedance

As we know, the total impedance of a voice coil is always the sum of the wire resistance, motional impedance and inductive impedance. In woofers, low frequencies are dominated by the motional impedance, center area of the operation band by the resistance, and the top end by the inductance. The frequency range covered by tweeters is generally narrower (about 1 decade), for which reason the motional and inductive impedances do not reach as dominant status as in a bass-midrange unit of a typical 2-way system. Yet even in tweeters, the motional impedance rises, when the resonant frequency is approached, to the same order of magnitude with the resistance; and at the upper edges of the hearing range, the inductive impedance reaches similar position.

The components of impedance differ in direction angle, so, in order to acquire an overall view, they must be analyzed in the complex plane. Figure 3.7 depicts, using Nyquist plot, the composition of the impedance of an F/C driver at different frequencies.

Based on earlier observations, the sum of the motional impedance Z_m and resistance R_c follows a circular locus, indicated by the dashed line, the diameter being equal to the motional impedance magnitude at the resonant frequency. This value is obtained from equation (3.8), as terms s^2 and k/m cancel out each other, leaving left $Z_m(\omega_0) = (Bl)^2/b$. The peak value of the total impedance, reached at the resonant frequency, is therefore (assuming the effect of inductance is negligible)

$$Z(\omega_0) = R_c + \frac{(Bl)^2}{b} \quad (3.12)$$

As frequency increases, the inductive impedance Z_i begins to deflect the locus of the total impedance more and more in the direction of the positive imaginary axis and finally also in the direction of the positive real axis.

Figure 3.7a shows the situation below the resonant frequency where the total impedance is inductive while Z_i is too small to be drawn. Figure b shows the situation slightly above the resonant frequency where the total impedance is capacitive and the contribution of Z_i begins to

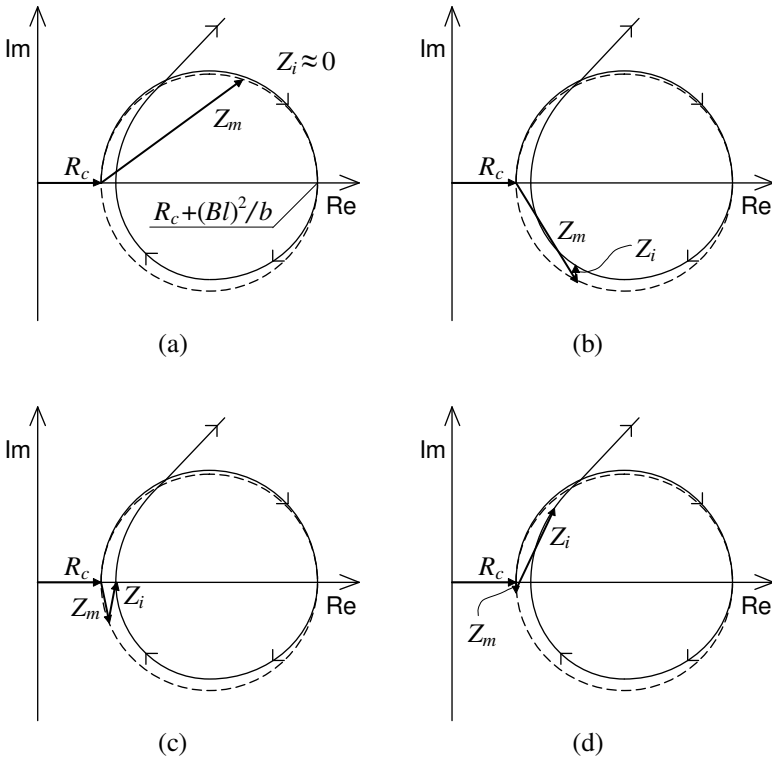

Figure 3.7. Impedance behavior of a driver in free air or closed cabinet. At low frequencies, the locus of total impedance follows a circular arc but deviates with increasing frequency, gradually, in the inductive direction. The diameter of the circle (dashed line) is $(Bl)^2/b$, where b is the damping constant. The composition of impedance is shown below the resonant frequency (a), somewhat above the resonant frequency (b), at the point of minimum impedance (c), and in the highest part of the operation band (d).

show up. In Fig. c, the total impedance is resistive and only a bit higher than R_c ; Z_m and Z_i being almost opposite to each other. In the case of Fig. d, frequency is so high that Z_i makes the total impedance strongly inductive again, while Z_m is very small. Along with Z_i , the total impedance continues its growth and remains inductive up to very high frequencies.

The above described applies, by its principles, also to high-frequency drivers, but especially in structures equipped with a rear chamber,

the behavior of the motional EMF can be more irregular in the resonance region, and besides the actual impedance tip, there may also appear other prominences. Ferrofluid, that is often used for voice coil cooling, in turn, strongly increases the damping coefficient b , making the impedance circle considerably smaller than shown in Fig. 3.7. Thus, ferrofluid lowers the impedance peak and reduces the Q value.

The essential behavior of the impedance magnitude of an F/C driver is shown in Fig.3.8a, the dashed line representing again voice coil resistance. The form of $|Z|$ corresponds to the model of Fig. 3.7. At f_c , that corresponds to the minimum point represented by Fig. 3.7c, $|Z|$ is generally yet 10-20% greater than R_c .

By looking at mere total impedance, one can easily get the impression that the effect of motional EMF would vanish at about f_c . Correspondingly, the effect of inductance would seem to be confined above frequency f_c . The truth shows up, however, from Fig. 3.7c, that shows how, at the mentioned frequency, Z_m and Z_i largely cover each other, having nevertheless considerable magnitude. It is even probable that in many high-sensitivity drivers, that are commonly used e.g. in orchestral and PA speakers*, the sum of $|Z_m|$ and $|Z_i|$ exceeds the voice coil resistance at *all* frequencies of the operation band.

Figure 3.8b depicts the behavior of the direction angle ($\angle Z$), corresponding to the magnitude graph of Fig. 3.8a. The angle has a positive (inductive) peak below the resonant frequency and a corresponding negative (capacitive) peak above it, as can be concluded from Fig. 3.7. The height of the peaks depends on the ratio of the circle's diameter and R_c .

It is of benefit, concerning amplifier operation, that the load impedance does not become excessively reactive at any frequency, that is, the absolute value of $\angle Z$ remains sufficiently low. This means, in practice, that the mechanical Q must be restricted if an F/C driver is to be easy matter for the amplifier. A moderate Q value also aids in the implementation of equalizer circuits for current-drive.

3.6 Motional Equations under Voltage Drive

In section 3.2, we derived, for an F/C driver, the transfer function from current to displacement, assuming frequency to be so low that mo-

* PA stands for "public address" and has originally denoted an announcement system. Nowadays the concept involves mainly amplification equipment used by performers.

tered according to the generalized Ohm's law, determined by the impedance Z . The transfer function from drive voltage to displacement, X/U , becomes now, using equations (3.4) and (3.13),

$$\begin{aligned} \frac{X}{U} &= \frac{X}{IZ} = \frac{Bl/m}{s^2 + \frac{b}{m}s + \frac{k}{m}} \cdot \frac{1}{R_c} \cdot \frac{s^2 + \frac{b}{m}s + \frac{k}{m}}{s^2 + \left[\frac{b + (Bl)^2/R_c}{m} \right] s + \frac{k}{m}} \\ &= \frac{Bl}{mR_c} \cdot \frac{1}{s^2 + \left[\frac{b + (Bl)^2/R_c}{m} \right] s + \frac{k}{m}} \end{aligned} \quad (3.14)$$

which is a 2nd-order low-pass function, as also expression (3.4).

By comparing result (3.14) to the standard form (2.5), it is observed that the characteristic frequency is the same as also in the current-drive case, i.e. expression (3.5). The Q factor, instead, changes totally. Using formula (2.4), we obtain now:

$$\begin{aligned} Q &= \frac{\sqrt{k/m}}{(b + (Bl)^2/R_c)/m} \\ &= \frac{\sqrt{km}}{b + (Bl)^2/R_c} \end{aligned} \quad (3.15)$$

So, in addition to the mechanical parameters, the Q of an F/C driver under voltage drive (i.e. total Q factor) also depends on the force factor and resistance.

Compared with the Q under current-drive, (3.6), expression (3.15) always yields a lower value, due to the term $(Bl)^2/R_c$, that parallels the mechanical damping constant b and represents an electrical damping constant, or simply, electrical damping. $(Bl)^2/R_c$ is generally greater than b , so the effect of electrical damping on the system's Q is conclusive.

Doubts cast upon the functionality of current-drive are most often based just on the lack of such electrical damping and the usually oversized Q , that results as the consequence.

Electrical damping is, however, a very paltry justification for such a supreme and decisive choice of policy that the driving

principle of loudspeakers presents, since the bass resonance only governs a small portion of the audio spectrum; and thus far, there has not been even proper effort to seek those solutions, based on active and passive processing as well as driver and enclosure techniques, by which the fundamental resonance can be reasonably controlled, without resorting to the filtering of current brought about by the motional impedance.

Formula (3.15) is also applicable when the amplifier does not act as an ideal voltage source but exhibits output resistance R_o . Then, one has to substitute $R_c + R_o$ in place of R_c since all resistance appearing in series is equal in effect. When R_o becomes very high, one ends up with equation (3.6) since ideal current-drive corresponds to infinite output resistance.

By setting b to zero in expression (3.15), we are left with so-called electrical Q factor (designated Q_e), that thus corresponds to a condition where there appears no mechanical damping force. Q_e may be expressed in terms of the mechanical Q (designated Q_m) as follows:

$$Q_e = \frac{\sqrt{km}R_c}{(Bl)^2} = \frac{\sqrt{km}}{b} \cdot \frac{R_c b}{(Bl)^2} = Q_m \frac{R_c}{Z(\omega_0) - R_c} \quad (3.16)$$

where relation (3.12) has been used.

In practice, Q_m is found by determining the Q of the motional impedance (method described in section 13.1). After this, Q_e is obtained from equation (3.16) without additional measurements. When Q_m and Q_e are known, the total Q can be calculated, on the grounds of equation (3.15), from the formula:

$$\frac{1}{Q} = \frac{1}{Q_m} + \frac{1}{Q_e} \quad (3.17)$$

Alternatively:

$$Q = \frac{Q_m Q_e}{Q_m + Q_e} \quad (3.18)$$

3.7 The Origin of Sound

So far, we have considered the motion of the diaphragm and related factors, but the goal is, of course, to understand and know the behavior

of the acoustic pressure, i.e. sound, radiated by the driver. In texts dealing with the generation and propagation of sound waves, it is customary to present the subject in terms of acoustic impedance, radiation impedance, and other rather abstract concepts and mostly for those who are already almost specialists. This kind of theoretical approach is, however, not very illustrative and not even necessary when seeking to characterize the pressure signal produced by a loudspeaker, for the subject can also be examined based on minimum-phase linear systems.

In the following, it is assumed that the loading on the driver diaphragm due to moving air mass can be ignored, which holds quite well unless the issue is about horn speakers.

It is known that the displacement of an ideal piston mounted in an infinite baffle* must become fourfold as frequency is halved, in order to keep sound pressure on the center axis constant. Thus, to accomplish flat frequency behavior, the displacement must be, in principle, inversely proportional to the square of frequency which just corresponds to the situation in a speaker driver when operating in the frequency region that is governed by the moving mass, that is, above the resonance region.

It is also known that, in the mentioned region, the pressure signal is, when leaving, in phase with the applied current, assuming that current regarded as positive tends to push the diaphragm forward. However, as the displacement is in opposite phase relative to current (as was noticed in section 3.2), the pressure must, in turn, be in opposite phase relative to the displacement.

On the above basis, it is evident that the transfer function from displacement to pressure corresponds, in the referred case of infinite baffle, to a double differentiator, so the pressure must, when generating, follow the second time derivative of the displacement, that is, acceleration. The baffle mentioned doesn't have to be planar; it is enough that the solid angle seen by the piston does not depend on distance at the wavelengths concerned. Thus, it can be stated:

The pressure radiated by a speaker diaphragm in its front is, as a main rule, directly proportional to the diaphragm's acceleration, not to the displacement or velocity, as is suggested in many interpretations. With sine wave, this implies, inter alia, that the leaving pressure reaches its maximum when the diaphragm is in its rearmost position, because the acceleration is

* Denotes a flat and rigid panel whose edges are in all directions so far as to not have any effect on the sound generated by a vibrator in the panel. The term is sometimes used incorrectly to denote a closed cabinet, which is, however, quite a different thing.

thus falls below the resonant frequency with a 2nd-degree slope, or 12 dB per octave.

From Fig. 2.3b it appears that the phase of acceleration and pressure (curve C) precedes the applied signal more and more, as frequency is lowered. The value of Q also affects the picture, as shown in Fig. 2.1b. At the resonant frequency, this phase lead is 90° which can cause unfavorable surprises with tweeters and midrange drivers if the phenomenon has not been duly taken into account in crossover filter design. Particularly in woofers, this inevitable phase shift causes low frequencies to be reproduced in advance of higher ones, in terms of phase. For an individual driver, amplitude and phase are always tied together according to the principle of minimum phase.

Figure 3.9 illustrates the phase relationships of an F/C driver using phasor diagrams. Acceleration, velocity, and displacement always stay at the same angle relative to each other but turn with respect to current. Figure 'a' depicts the situation far below the resonant frequency where displacement and current are almost in phase, acceleration being a half cycle ahead of them. At the resonance (Fig. b), velocity reaches its maximum value and becomes in-phase with current. Far above the resonant frequency (Fig. c), in turn, acceleration is virtually coincident with current, displacement becoming very small. The motional EMF always accompanies the velocity phasor.

Besides frequency analysis, it is also informative to take a look at the

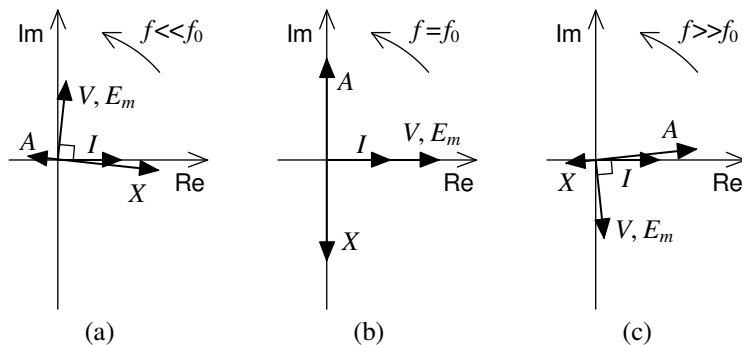

Figure 3.9. Phasor diagram of a speaker driver at three different frequencies (f_0 = resonant frequency), current I serving as the reference. As the phasors rotate counterclockwise, their real parts represent the instantaneous values. Acceleration (A) and velocity (V), and respectively, velocity and displacement (X) are, by definition, always perpendicular to each other. Phasor lengths have no significance in this context, except in comparison between the Figures.

time behavior of a driver, for the actual movement of the diaphragm, in transient reproduction, doesn't really coincide with common imagery.

We take as an example the test signal shown in Fig. 3.10a, consisting of two symmetric rectangular pulses, to represent current applied to the voice coil. (We ignore that, in practice, no signal source is able to generate discontinuities.) The driver is assumed to operate ideally for all frequencies, so that the acceleration of the diaphragm perfectly follows this signal.

The velocity of the diaphragm, that is obtained as the integral function of the acceleration, then varies according to the triangular shape of Fig. b, staying non-negative all the time (assuming the diaphragm was initially at rest). The displacement, that in turn is obtained as the integral of the velocity, thus behaves as shown in Fig. c. During the positive input pulse, the displacement increases along an upward-opening parabola curve, and during the negative pulse, the increase still continues, but now along a downward-opening parabola.

Thus, in this ideal case, the diaphragm stays, after the signal, permanently in a deviated position (solid line) because the frequency region reproduced by the driver has no lower limit. In practical drivers, however, there always has to be a spring that effects the return of the diaphragm toward the rest position (dashed line), thus limiting the lower cut-off frequency. The behavior of the displacement is even a bit surprising

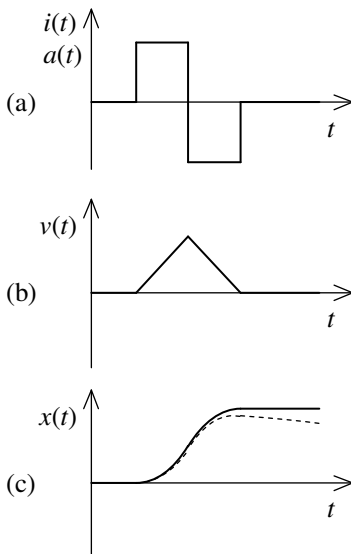

Figure 3.10. Time behavior example of an ideal driver. a) Test signal congruent with diaphragm acceleration. b) Velocity corresponding to the acceleration of Fig. 'a'. c) Displacement corresponding to the previous graphs (solid line) and one achievable with a practical driver (dashed line).

since, by looking at the curve of Fig. c, it does not readily come to mind that as the outcome is a sound signal shown in Fig. 'a'.

When discussing the transient properties, it is often worried how the diaphragm behaves when a signal suddenly stops, and how the consequent post-oscillations are curbed. To produce a sound, in general (e.g. in musical instruments), always requires, however, a vibrating surface or equivalent that has, at every moment, certain displacement, velocity, and acceleration. A sudden stopping of a sound would require, in practice, that these and also the derivative of the acceleration, the next derivative, and so on, should somehow be brought to zero at the same moment. This is an impossible occurrence which also shows up from Fig. 3.10 in that returning the diaphragm home requires new velocity and new acceleration. Hence, no signal originating from any practical sound source ever stops abruptly but always through exponential decay since only on the exponential function all its derivatives decay at the same rate.

According to a common thought, especially propagated by advertisers, the mass of the diaphragm should be as low as possible, in order that it could "follow" rapid signal changes and thus reproduce strokes accurately. However, based on Fig. 3.10c, one has to ask: For what is low mass needed here? In what way does the smallness of mass help, even when desiring to reproduce the unrealistic rectangular signal of Fig. 3.10a? The answer is simple:

The magnitude of the mass of the moving parts of a driver has directly nothing to do with how accurately the driver is able to reproduce various transient shapes. The mass only affects directly the overall sensitivity and resonance properties, and excessive lightness is even disadvantageous due to heightened resonant frequency.

The lightness of the diaphragm material might give some benefit, in terms of sound quality, in the sense that at high accelerations the tensile forces stressing the diaphragm would stay smaller, thus reducing deformations. On the other hand, by allowing greater mass, the rigidity of the diaphragm can be substantially improved, so the above aspect for small mass doesn't carry very far either.

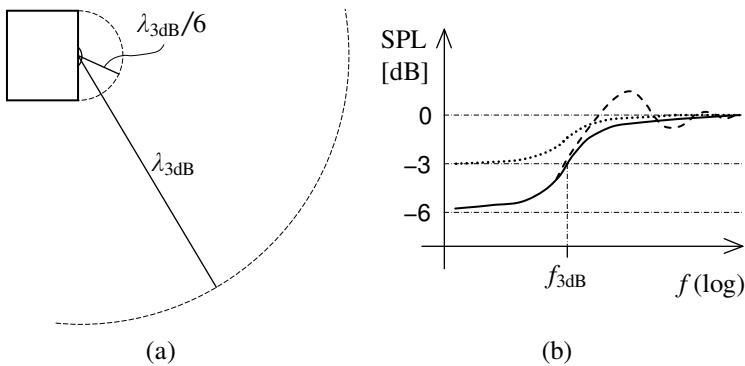

Figure 3.11. a) The wavelength corresponding to the center frequency of the cabinet-induced baffle step proportioned to the width of the front panel. b) General behavior of the baffle step. Solid line: the effect of bare baffle step on the sound pressure measured from the front side (SPL = sound pressure level). Dashed line: a more realistic response, where is seen alternation caused by edge reflections. Dotted line: total response into all directions (power response).

however, more that indicated by the dashed line since the diffractive reflections oriented from the cabinet edges to the listening point cause boosts and cuts when merging with the directly coming radiation.

The dotted line represents the total response, that involves all directions and is also proportional to the total acoustic power and is therefore also referred to as the *power response*.

The baffle step appears only 3 dB high in the power response since the radiation oriented to the back half partially makes up for the lack introduced in the front half radiation at low frequencies. So, as the front pressure drops to half, an other sound field of corresponding intensity develops in the back side which doubles the total radiated power and thus increases the power response by 3 dB, compared to a case where the back radiation is not taken into account. (An increase of 3 dB always denotes a doubling of power and a multiplication of level by $\sqrt{2}$.) The power response doesn't exhibit undulations caused by edge diffractions because the reflections do not increase or decrease the total power of radiation at any frequency.

The increase in power response due to decreasing solid angle also implies an increase in power efficiency since the input power remains unchanged. The phenomenon is utilized in horn-loaded speakers, whose efficiencies are in the class of tens of percents, while a typical figure in

a hifi driver radiating into half-space remains below 1 percent. The rise in radiation effectiveness also increases the stress exerted on the diaphragm which can introduce even distortion unless the driver is suited for horn loading.

At high frequencies, the radiation field obtained also narrows due to the driver's own directivity since radiation originating from different parts of the diaphragm arrives to a point aside from the center axis in different phase, so the sound attenuates the more the higher the frequency is and the farther one goes from the center axis direction.

Figure 3.12a depicts the outline of a typical frequency response of a cone driver up from the mid-frequencies in three different directions, in conditions corresponding to an infinite baffle, and using current-drive. The steep fall of sound pressure in the side directions also limits, for its part, the usable frequency band of the driver. Curves taken at 60° off-axis can also be used for rough estimation of the power response since this direction represents, in practice, best the whole half-space.

At high frequencies, the diaphragm doesn't act uniformly but breaks up into differently vibrating regions since the velocity of sound in the diaphragm material itself is generally not sufficient to keep the whole cone at the same phase. At the same time, there also occurs some disconnection of the diaphragm so that only the central part of the cone vibrates with the voice coil, the other part remaining as a passive flare. This shrinking of the effective area is largely compensated by a reduction in the moving mass, but, as frequency rises further, sound pressure

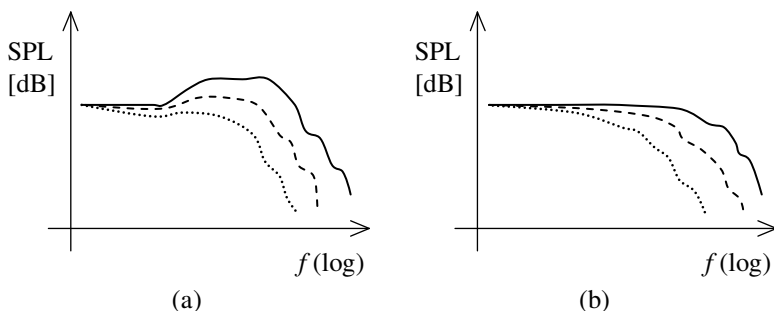

Figure 3.12. Effect of directivity on the performance of a cone driver at high frequencies. a) General behavior of the frequency response under constant current; directly in the front (solid line), at 30° angle (dashed line), and at 60° angle (dotted line). Because of the horn effect caused by the cone, the upper end of the reproduction region tends to be accentuated. b) Curve set corresponding to Fig. 'a' without the horn effect.

finally collapses also on the front axis.

At high frequencies, the horn action of the cone easily causes an extensive accentuation in the frequency response, as sketched in Fig. 3.12a. On voltage drive, the phenomenon is not as prominent due to the filtering effect of voice coil inductance. This accentuation of high frequencies limits the suitability of many present-day drivers, designed solely for voltage, to be current-operated. Without the horn effect, the response on current-drive would stay, in principle, flat up to the final fall-off (Fig. 3.12b).

The material and size of the diaphragm have a remarkable effect on how pronounced this high-tone boost appears. Polypropylene, that has good internal damping, seems to perform in this regard better than many other substances. In metal cones (aluminum, magnesium), the velocity of sound is so high that any horn effect virtually cannot arise, but due to strong resonance in the treble region, these are not very usable at least for passive current-drive applications.

With small cones, the rise in sensitivity is usually of the order of a few decibels and is compensated, at least partially, by the increasing directivity. In large drivers, however, the rise is often as high as 10 dB which calls for appropriate compensation or low enough crossover frequency.

3.9 Power Consumption

Of the quantities describing loudspeaker properties, for many it is power that first comes to mind. Consequently, in the marketing of stereo sets, increasingly bizarre power markings are employed to make an impression; but as a matter of fact, the power limits usually specified for both drivers and complete speakers are some of the most meaningless parameters and fully dependent on the way of definition.

Measurements of power handling capacity are generally performed using a noise signal of specific frequency distribution and crest factor, assuming yet that the load is a resistance equal to the rated impedance. The power ratings determined may perhaps give some reference relating to the amplifier power that can be recommended with a certain type of program material; but instead, they tell nothing about how loud sound the speaker is able to produce without being distorted, and often not even the maximum power tolerated by the voice coil.

It is also quite misleading that the power specified for a driver is not based on the power consumed by the driver itself but on the consump-

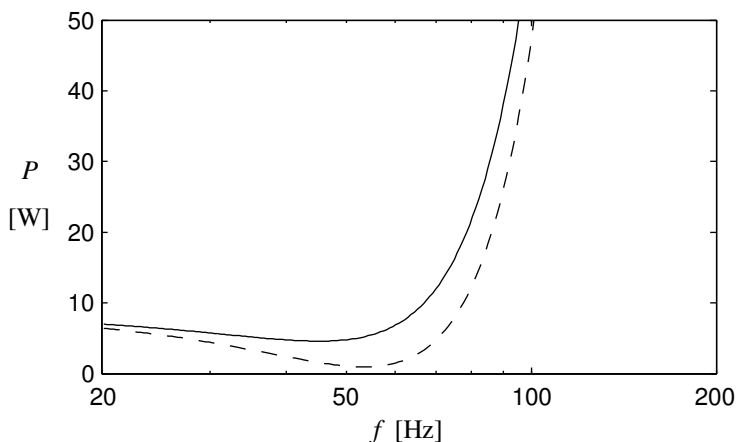

Figure 3.13. Power consumption vs. frequency in a typical 8-inch woofer in closed 40-litre enclosure while cone excursion is kept at maximum (5 mm in one direction). Solid line indicates total power and dashed line power dissipated by the voice coil. Parameters used: $Bl = 9$ N/A, $m = 0.025$ kg, $k = 3000$ N/m (equivalent volume 80 l, $C_{ms} = 0.001$ m/N), $b = 3$ Ns/m, and $R_c = 6$ Ω .

use of equations (3.4) and (3.8) for a typical 8-inch woofer that has been mounted in a 40-litre enclosure and has a linear excursion of ± 5 mm.

Rated power for this kind of driver is most often about 100 W, but the excursion-limited power consumption remains here, below and near the resonant frequency (55 Hz), below 10 watts, embarking on steep rise only at higher frequencies (solid line). It is also interesting that the power heating the voice coil (dashed line) is only 1 W at lowest.

Moreover, these powers are valid for sine wave, whose crest factor, i.e. the ratio of peak value to RMS value, is $\sqrt{2}$. In real-world sound signals, the crest factor is considerably higher which further reduces the average power demand in the bass region. Hence, the power handling capacity is quite a useless property at least for speakers intended for the mere low-bass range (subwoofers), that are often marketed by power figures of the kilowatt class.

An interesting phenomenon relating to power consumption is the improvement of the speaker's efficiency at low frequencies when the number of drivers increases.

When a second driver is added near the first and fed by the same signal, the total input power for sure doubles (ignoring negligibly minor changes in the motional impedance). The acoustic power radiated also

doubles if the wavelength is so small that the phase difference between the waves sent by the drivers is, all directions regarded, random; that is, the waves are not mutually coincident, except in some directions, like on the front axis.

If, by contrast, the wavelength is so large that the waves sent by the drivers are in phase regardless of the direction, the pressure is in all directions double compared to the radiation of a single driver, denoting fourfold acoustic power. Thus, the efficiency doubles, at low frequencies, due to the presence of the second driver.

This being the case, one may well ask: if the efficiency of a loudspeaker seems to be, at certain frequencies, directly proportional to the number of drivers, can we not, by adding drivers, finally achieve an efficiency greater than one? The frequency can namely always be chosen so low that the condition for the wavelength is satisfied.

The explanation abides in that, as the number increases, the air loading exerted on the diaphragm of each driver also increases, adding to the effective moving mass and thus decreasing the diaphragm's motion, until finally, when the number is still doubled, the acoustic power only doubles instead of becoming fourfold, thus leaving the efficiency unchanged.

Using several drivers is nevertheless, from the standpoint of power consumption, generally a more advantageous solution than increasing the size of a single driver.

3.10 Microphone EMF

The operation of transducers working on the electro-dynamic principle is always reversible, that is to say, the same structure that acts as a loudspeaker also acts as a microphone, and vice versa. This microphone feature of loudspeakers (and correspondingly, the loudspeaker feature of microphones) is thus in action at every moment, whether we wanted it or not. The diaphragm motion arisen by external pressure alternation namely always causes its own EMF component, which summates with the motional EMF deriving from the loudspeaker action.

The mechanical model of Fig. 3.3b can also be used when the driver operates as a microphone. The only difference is that the force F is not generated by current but by the acoustic pressure acting on the diaphragm.

We will consider an enclosed driver that is not loaded electrically and that is small in size with respect to wavelength. Instead of force

(3.1), the diaphragm is now being exerted by force $F = -Sp$, where S is the effective diaphragm area and p is the pressure acting in front of the diaphragm. (Positive pressure gives rise to backward force.) Constant Bl in equation (3.3) is now replaced by $-S$ and current i by pressure p . The transfer function from acoustic pressure to displacement thus becomes, corresponding to equation (3.4),

$$\frac{X}{P} = - \frac{S/m}{s^2 + \frac{b}{m}s + \frac{k}{m}} \quad (3.20)$$

By the same procedure that was used to obtain equation (3.8), we can now derive the relationship between the EMF of the microphone (labeled E_p) and the pressure:

$$\frac{E_p}{P} = - \frac{SBl}{m} \cdot \frac{s}{s^2 + \frac{b}{m}s + \frac{k}{m}} \quad (3.21)$$

Thus, the frequency response of a sealed microphone element follows, in principle, a corresponding 2nd-order band-pass function as the motional impedance of the element.

How, then, is it possible to achieve flat frequency response with dynamic pressure microphones altogether? Very good result is indeed not easily achieved, but, by making the Q value very low (< 0.2) and by choosing the resonant frequency appropriately, quite a useful frequency range can still be obtained. The response is also usually modified with extraneous cavities.

Another major class of dynamic microphones is formed by so-called pressure gradient microphones, that in fact respond to particle velocity, instead of pressure, and correspond, by their principle, to a free or openly enclosed speaker driver. In this kind of structure, there is established, between the front and back surfaces of the diaphragm, acoustic cancellation, that in loudspeaker use causes the well-known 1st-degree roll-off in the front-measured frequency response, down from a certain cut-off frequency. In microphone use, however, the corresponding phenomenon is of advantage because the differentiator action it introduces turns the aforementioned band-pass response into high-pass, which often serves the purpose better.

Transfer function (3.21) can also be substantially simplified if frequency is confined to be distinctly above the resonance point. Confor-

4

THE CONSEQUENCES OF VOLTAGE DRIVE

When listening to speech or music through a conventional, even of high-quality, loudspeaker system, we quite clearly detect that the sound emanates from loudspeakers. A kind of electrical stamp or characteristic in the sound always reveals that one is experiencing an electronically reproduced image and not a genuine, live performance. This general impression of roughness, that could be called something like synthetic dressing, does not disappear even with the most expensive equipment and harms especially acoustic music since instruments do not sound as they do in actuality, and choral voices, for example, clot and become easily distorted. Amongst hifi hobbyists, an often used term is listening fatigue, which is related to lacks in sound quality but can seldom be linked to any measurable explanation.

What is the reason that, even in this age of communication technology, a more lifelike sound reproduction has not been achieved? Solutions have been sought mostly by increasing the number of sound channels and by digital processors striving to convey spatial information, but the factors essentially affecting the operation accuracy of the speaker driver itself, the electromotive forces, have been left without proper attention although some discussion relating to current-drive experiments has been seen in the past decades.

As it appeared in the previous chapter, the electromotive forces are a significant part of the driver's total voltage for all frequencies. In the following, we will examine what kind of destruction these parasite voltages and some related factors produce when they are freely allowed to merge with the applied signal. Let's therefore let the cat out of the bag.

4.1 Circulation of the Electromotive Forces

As was already found, an electro-dynamic transducer itself doesn't know whether it is intended to convert electrical signal to mechanical motion or do the reverse, so it serves both offices all the time. When dealing with a low-impedance source or load, however, these two functions will not remain separated from each other but intermingle in a way that is not acceptable from the standpoint of either goal. Taking into account how poor usually is the quality of the microphone signal generated by loudspeakers, it is truly unfortunate how indifferently its effects have been taken and how little is generally known about it.

The motional EMF induced in the voice coil, discussed in sections 3.3 and 3.10, follows at every moment the velocity of the voice coil, in principle, according to equation (3.7).

Figure 4.1 shows how this EMF (e) acts in the circuit formed by the amplifier output and speaker driver. Figure 'a' represents the situation on voltage drive where the EMF generated by the driver appears in series with the amplifier output voltage, thus affecting essentially the development of current. In addition to the current component u_o/R_c , representing the applied signal, there also flows an extraneous current component, e/R_c , that can in many respects be regarded as a disturbance factor. Because e is, in practice, almost of the same order of magnitude as u_o , current e/R_c has also a very pivotal role in the development of the drive force actuating the voice coil.

Figure 4.1b represents, respectively, a driver operated by a current

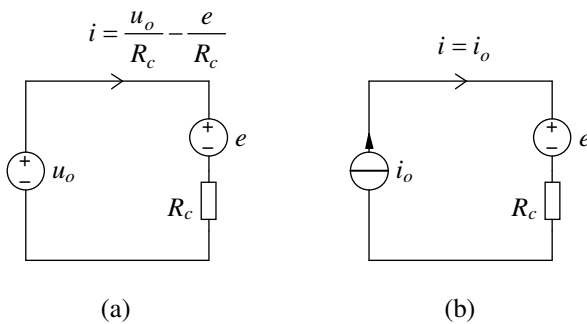

Figure 4.1. The composition of current in a speaker driver, with voltage source feed (a) and current source feed (b). On voltage drive, the current is affected, besides the applied voltage u_o , by the driver's electromotive force e . Instead, on current-drive, the resulting current is exactly what is fed (i_o).

source. Now, the EMF introduced in the voice coil is not able by any means to affect the flow of current, which is determined solely by the feeding source. As the current is forced, the EMF only manifests as an additional voltage component at the driver's terminals but is not involved in voice coil actuation.

Consequently, under voltage drive, the voltage applied as though first effects a certain current, that sets the voice coil and diaphragm in motion. This motion, in turn, induces an EMF, which causes its own current component, that is limited only by the voice coil resistance (R_c). This current, in turn, again actuates the voice coil, in which is now generated a new EMF, from which ensues new current, and so on. Thus, in better words:

A loudspeaker circuit operating on voltage drive exhibits a feedback effect where the EMF deriving from voice coil motion directly summates with the voltage applied to the driver, so that the resulting current is a mixture of the original signal and a spurious signal corrupted by the speaker's own mechanical, electrical, and acoustic properties and circulated in the feedback process.

A corresponding feedback mechanism is in action also with the inductive EMF.

Imagine whatever non-ideality or interference factor that strikes the operation of the driver, introducing an EMF. In the case of Fig. 4.1a, this EMF always effects a corresponding disturbance current because voltage source u_o appears as a short-circuit for other sources.

As the same disturbance EMF appears in the Fig. b circuit, the outcome is entirely different since the current source i_o is seen by the EMF as an open circuit, thus eliminating the generation of unwanted currents and keeping the voice coil operation immune not only to own spurious voltages but also to other adverse factors discussed later.

4.2 Microphone Feedback

A loudspeaker diaphragm produces sound by the same principles both forward and backward. However, inside an enclosure, the sound pressure is, at bass and lower midrange frequencies, many times higher than outside because the interior pressure is not able to spread to the ambience and because the interior surfaces close to the driver affect like